



Vehicular Antenna Test Methodology

5GAA Automotive Association
Technical Report



CONTACT INFORMATION:

Executive Manager – Thomas Linget
Email: liaison@5gaa.org

MAILING ADDRESS:

5GAA c/o MCI Munich Neumarkter Str. 21
81673 München, Germany
www.5gaa.org

Copyright © 2024 5GAA. All Rights Reserved.

No part may be reproduced except as authorised by written permission. The copyright and the foregoing restriction extend to reproduction in all media.

VERSION:

2

DATE OF PUBLICATION:

23 April 2024

DOCUMENT TYPE:

Technical Report

EXTERNAL PUBLICATION:

Yes

DATE OF APPROVAL BY 5GAA BOARD:

12 February 2024

Contents

	Foreword.....	5
	Introduction.....	6
1	Scope	7
2	References	8
3	Definitions, symbols and abbreviations.....	9
	3.1 Symbols.....	9
	3.2 Abbreviations.....	9
4	Principles of measurement setups.....	11
	4.1 Measurement environments.....	11
	4.2 Coordinate system/angle definition.....	12
	4.3 Measurement frequencies.....	13
	4.4 Test volume.....	14
	4.5 Environmental conditions.....	15
	4.6 Test-range acceptance criteria.....	15
	4.6.1 Test range acceptance method.....	17
	4.6.2 Test range acceptance criteria.....	21
5	Antenna pattern measurements.....	23
	5.1 Measurement methodologies/definitions.....	23
	5.1.1 Measurement equipment.....	25
	5.1.2 Near-field test method.....	25
	5.1.3 Far-field test method.....	26
	5.1.4 Path loss calibration.....	26
	5.1.5 Uncertainty considerations.....	26
	5.2 Measurement procedures.....	27
	5.2.1 Near-field test procedures.....	27
	5.2.2 Far-field test procedures.....	27
	5.2.3 Measuring angle range definition.....	28
	5.2.4 Antenna gain measurements.....	28
	5.2.5 Vehicles implementing transmit and/or receive antenna diversity.....	28
	5.3 Result analysis.....	29
	5.3.1 Vehicular communication characteristics.....	29
	5.3.2 Analysis angle range definition.....	30
	5.3.3 Gain normalisation.....	32
	5.3.4 Average gain.....	34
	5.3.5 Peak gain.....	36
6	OTA system measurements.....	37
	6.1 Measurement methodologies/definitions.....	38
	6.1.1 Measurement equipment.....	40
	6.1.2 Calibration.....	40
	6.1.3 Uncertainty considerations.....	40
	6.2 Measurement procedures.....	40
	6.2.1 Measuring angle range definition, OTA-conventional method.....	40
	6.2.2 Measuring angle range definition, OTA-combinational method.....	41
	6.2.2.1 Measuring angles at selected combinations.....	41
	6.2.3 OTA radiated power.....	41
	6.2.3.1 GSM.....	42

6.2.3.2	UMTS	42
6.2.3.3	LTE	42
6.2.3.4	5G NR	43
6.2.3.5	Direct communication	43
6.2.3.6	Vehicles implementing transmit antenna diversity	44
6.2.4	OTA receiver performance	44
6.2.4.1	GSM	44
6.2.4.2	UMTS	45
6.2.4.3	LTE	45
6.2.4.4	5G NR	45
6.2.4.5	Direct communication	46
6.2.4.6	GNSS	46
6.2.4.7	Vehicles implementing receive antenna diversity	48
6.3	Result analysis	49
6.3.1	Spatially averaged quantities	49
6.3.2	Analysis angle range definition	50
6.3.3	Combination of results for OTA-combinational method	50
6.3.3.1	Radiated power	50
6.3.3.2	Isotropic sensitivity	51
6.3.4	Calculation of spatially averaged quantities	52
6.3.4.1	Partial radiated power	53
6.3.4.2	Partial isotropic sensitivity	53
6.3.5	Peak EIRP	54
Annex A:	Criteria to determine a reduced D	55
A.1	Definitions	55
A.2	Criteria for using a smaller D	55
A.2.1	Convergence criterion (option 1)	56
A.2.1	Convergence criterion (option 2)	57
Annex B (informative):	Survey and analysis of existing work in the relevant SDOs	58
B.1	3GPP	58
B.2	CTIA	59
B.3	ETSI	59
B.4	CCSA	59
B.5	IEEE	59
B.6	Conclusion	60
Annex C:	Measurement uncertainty explained	61
Annex D:	Uncertainty considerations	62



Foreword

This Technical Report has been produced by 5GAA.

The contents of the present document are subject to continuing work within the Working Groups (WG) and may change following formal WG approval. Should the WG modify the contents of the present document, it will be re-released by the WG with an identifying change of the consistent numbering that all WG meeting documents and files should follow (according to 5GAA Rules of Procedure):

x-nnzzzz

- (1) This numbering system has six logical elements:
 - (a) x: a single letter corresponding to the working group:
where x =
T (Use cases and Technical Requirements)
A (System Architecture and Solution Development)
P (Evaluation, Testbed and Pilots)
S (Standards and Spectrum)
B (Business Models and Go-To-Market Strategies)
 - (b) nn: two digits to indicate the year. i.e. ,17,18 19, etc
 - (c) zzzz: unique number of the document
- (2) No provision is made for the use of revision numbers. Documents which are a revision of a previous version should indicate the document number of that previous version
- (3) The file name of documents shall be the document number. For example, document S-160357 will be contained in file S-160357.doc

Introduction

The rising demand of connected vehicles as well as the ongoing deployment of vehicle-to-vehicle communication has shown that a unified measurement procedure for the communication subsystem antenna can add benefits for the development of vehicular communication systems. A unified measurement procedure for vehicular antennas (antennas permanently mounted on vehicles) will also ensure conformity assessments of the various regional standards are handled transparently.

5GAA, as an alliance connecting the automotive and telecom domains, developed a methodology to test vehicular antennas for communication and associated aspects (e.g. GNSS). Such a methodology can act as a commonly agreed test procedure for antenna communication subsystems. It is also expected to improve the accuracy of conformity assurance procedures for such vehicular systems.

The developed methodology should be understood as a tool to optimise testing efforts and provide measures to validate antennas based on the vehicle's form factors and special characteristics.

1 Scope

The present document defines a standardised test method and metrics for vehicular antennas with the dominant emittance outside the vehicle:

- ▶ Vehicular antennas for telecommunications (2G, 3G, 4G, 5G (< 7.125GHz))
- ▶ Vehicular antennas for direct communication between vehicles and vehicles to road infrastructure (operation in designated ITS frequency spectrum (5.9GHz range))
- ▶ GNSS-Antennas

It contains:

- ▶ Principles of measurement setups:
 - Definition of environment/ground materials
 - Type/configuration of measurement equipment
 - Calibration requirements
- ▶ Measurement configurations:
 - Definition of applicable elevation and azimuth ranges
 - Measurement types:
 - Passive at component level (antenna element at its installation location at the vehicle)
Measured values: e.g. realised gain
 - Active at system level (antenna element at its installation location at the vehicle + cabling + on board control unit)
Measured values: e.g. radiated power, isotropic sensitivity
 - Combinations of passive and active
Resulting values: e.g. radiated power, isotropic sensitivity
 - Data processing (e.g. near-field/far-field transformation)
- ▶ Considerations of uncertainties in measurement results
- ▶ Test procedures
- ▶ Processing of measurement results (e.g. grouping, averaging, integral quantities)

Existing antenna test procedures/specifications were reviewed for applicability and adopted where useful.

The methods and setups described in this document assume that the whole vehicle is considered as the device under test (DUT) for radiated measurements (i.e. passive antenna pattern and active over-the-air (OTA) system). Therefore the term vehicle under test (VUT) will be used throughout the document.

2 References

The following documents contain relevant information which is referenced to in this technical report.

- References are either specific (identified by date of publication, edition number, version number, etc.) or non-specific.
- For a specific reference, subsequent revisions do not apply.
- For a non-specific reference, the latest version applies.

- | | |
|------|---|
| [1] | IEEE Std. 149-2021, 'IEEE Recommended Practice for Antenna Measurements', September, 2021 |
| [2] | 5GAA TR P-180092, 5G Automotive Association, Working Group Evaluation, test beds and pilots: 'V2X Functional and Performance Test Procedures – Selected Assessment of Device to Device Communication Aspects' |
| [3] | 3GPP TS 36.521-1 V16.4.0 (2020-03), 3rd Generation Partnership Project; Technical Specification Group Radio Access Network; Evolved Universal Terrestrial Radio Access (E-UTRA); User Equipment (UE) conformance specification; Radio transmission and reception; Part 1: Conformance Testing (Release 16) |
| [4] | ETSI EN 302 571 V2.1.1 (2017-02), Intelligent Transport System (ITS), Radiocommunications equipment operating in the 5 855 MHz to 5 925 MHz frequency band, Harmonised Standard covering the essential requirements of article 3.2 of Directive 2014/53/EU |
| [5] | IEEE Std 1720™-2012, 'IEEE Recommended Practice for Near-Field Antenna Measurements' |
| [6] | 3GPP TS 34.114 V12.2.0 (2016-09); 3rd Generation Partnership Project; Technical Specification Group Radio Access Network; User Equipment (UE) / Mobile Station (MS) Over The Air (OTA) antenna performance; Conformance testing (Release 12) |
| [7] | 3GPP TS 37.544 V14.7.0 (2018-12); 3rd Generation Partnership Project; Technical Specification Group Radio Access Network; Universal Terrestrial Radio Access (UTRA) and Evolved Universal Terrestrial Radio Access (E-UTRA); User Equipment (UE) Over The Air (OTA) performance; Conformance testing (Release 14) |
| [8] | 3GPP TS 34.121-1 V16.2.0 (2019-09); 3rd Generation Partnership Project; Technical Specification Group Radio Access Network; User Equipment (UE) conformance specification; Radio transmission and reception (FDD); Part 1: Conformance specification (Release 16) |
| [9] | 3GPP TS 37.571-1 V17.1.0 (2023-06); 3rd Generation Partnership Project; Technical Specification Group Radio Access Network; User Equipment (UE) conformance specification for UE positioning; Part 1: Conformance test specification (Release 17) |
| [10] | 3GPP TS 37.571-5 V17.1.0 (2023-06); 3rd Generation Partnership Project; Technical Specification Group Radio Access Network; User Equipment (UE) conformance specification for UE positioning; Part 5: Test scenarios and assistance data (Release 17) |
| [11] | National Marine Electronics Association (NMEA) 0183 standard, Version 4.10 November 2008 |
| [12] | 3GPP TS 38.561 V17.0.0 (2024-01); 3rd Generation Partnership Project; Technical Specification Group Radio Access Network; NR; User Equipment (UE) conformance specification; UE TRP (Total Radiated Power) and TRS (Total Radiated Sensitivity) requirements and test methodologies for FR1 (NR SA and EN-DC); (Release 17) |

3 Definitions, symbols and abbreviations

3.1 Symbols

For the purposes of the present document, the following symbols apply:

c_0	Speed of light
D	Size of antenna aperture
D_{reduced}	Size of antenna aperture complying with the criterion defined in Annex A
f	Frequency
G	Antenna gain
H	Height of the verification volume
Δh	Discretisation distance of verification volume height
P	Power
pol	Polarisation
R	Measurement distance
ϕ	Azimuth angle in the spherical coordinate system
λ	Wavelength
θ	Zenith angle in the spherical coordinate system

3.2 Abbreviations

For the purposes of the present document, the following abbreviations apply:

3GPP	3rd Generation Partnership Program
AUT	Antenna Under Test
BER	Bit Error Rate
CCSA	China Communications Standards Association
CTIA	Cellular Telecommunications and Internet Association
CW	Continuous Wave
DUT	Device Under Test
EIRP	Equivalent Isotropic Radiated Power (far-field metric)
EIS	Equivalent Isotropic Sensitivity (far-field metric)
ETSI	European Telecommunications Standards Institute
FDD	Frequency Division Duplexing
FF	Far Field
HLP	Horizontal Linear Polarisation
HPBW	Half Power Beam Width

ITS	Intelligent Transport System
ITU	International Telecommunication Union
LHCP	Left Hand Circular Polarisation
LTE	Long Term Evolution
NF	Near Field
NHPIS	Near Horizon Partial Isotropic Sensitivity
NHPRP	Near Horizon Partial Radiated Power
NZPIS	Near Zenith Partial Isotropic Sensitivity
NZPRP	Near Zenith Partial Radiated Power
OBU	On-Board Unit
OTA	Over The Air
PIS	Partial Isotropic Sensitivity
PRP	Partial Radiated Power
RBER	Residual Bit Error Rate
RF	Radio Frequency
RHCP	Right Hand Circular Polarisation
SDO	Standards Developing Organisations
tbid	To be defined
TIS	Total Isotropic Sensitivity
TRP	Total Radiated Power
UPHIS	Upper Hemisphere Isotropic Sensitivity
UPHRP	Upper Hemisphere Radiated Power
V2I	Vehicle to Infrastructure
V2P	Vehicle to Pedestrian
V2V	Vehicle to Vehicle
V2X	Vehicle to everything
VH	Vehicle Harness
VLP	Vertical Linear Polarisation
VNA	Vector Network Analyser
VUT	Vehicle Under Test
WCDMA	Wideband Code Division Multiple Access

4 Principles of measurement setups

4.1 Measurement environments

Several measurement environments are known to test vehicular antennas:

- a) IEEE 149.2021 [1] summarizes in chapter 4.4 different types of indoor ranges: "Indoor antenna ranges are enclosed facilities that mimic or simulate a free-space condition. ... Internal surfaces of the room or chamber should be lined with RF absorber to help minimize reflections into the test zone...". This document focuses on rectangular anechoic chambers. During the course of this Technical Report the term rectangular anechoic chamber will be replaced by full anechoic chamber.
- b) The shielded chamber with metallic ground is almost the same as the full anechoic chamber except the floor is made of a perfect conductive surface instead of being covered with high-quality absorbing material.
- c) The free space antenna test range is an outdoor facility and typically consists of a metallic ground. It may be weather protected by a radome. The area surrounding the system is free from reflecting obstacles like buildings, trees or walls.

The measurement environment needs to allow to determine the vehicular antenna's far-field characteristics. Examples of such characteristics are the free-space radiation pattern, antenna gain, radiated power, received sensitivity, Equivalent Isotropic Radiated Power (EIRP), Equivalent Isotropic Sensitivity (EIS).

The minimum measurement distance R for far-field measurements of vehicular antennas is given by:

$$R > \frac{2D^2}{\lambda} \quad \text{Equation 1}$$

λ represents the wavelength corresponding to the measurement frequency f and is determined by

$$\lambda = \frac{c_0}{f} \quad \text{Equation 2}$$

c_0 = speed of light in vacuum.

D represents the size of the antenna aperture. The size of the antenna aperture is affected by the antenna type, mounting position and objects nearby. On vehicles, such objects can be roof rails, window openings, mirrors, housings of sensors, components relevant to the vehicle's structure and so on. As not all objects affect the antenna radiation pattern, and their impact on the antenna aperture is known, the largest dimension of the vehicle is taken in order to define D .

As an alternative to far-field measurements, as defined above, measurements can be performed also at shorter distances than R if appropriate mathematical manipulations are applied to the raw amplitude and phase data. The results of such near-field measurements must be equivalent to far-field data after the mathematical

manipulations. The mathematical manipulations must be taken into account in the evaluation of the measurement uncertainty.

When OTA measurements are performed in the near-field over the complete sphere no extensive mathematical manipulation of the measured data may be needed. The OTA performance parameters can be directly derived from the measured power density if the uncertainty associated with the close measurement distance is taken into account in the overall measurement uncertainty budget. The uncertainty associated with measurement distance can be estimated experimentally. Some terms that should be considered are the offset of the antenna phase center and the influence of the probe. Under the conditions and criteria defined in Annex A.2, a D_{reduced} could be used in order to improve test time (i.e. increasing the grid step size of near-field and far-field test methods), or to allow a shorter minimum distance R (for far-field test setups). Annex A provides two criteria which are recommended for determining an acceptable D_{reduced} . The final results of a measurement campaign should always refer to a full vehicle size test and the test volume definition in 4.4.

4.2 Coordinate system/angle definition

The spherical coordinate system referred to in this Technical Report, the evaluation coordinate system, is depicted in Figure 1a). Besides the definition of the coordinate system, it is necessary to define the two polarisations (Theta- and Phi polarisation) to be used for measuring the total field at each point. Two rotational axes are used to identify them, such that the Phi polarisation is along the direction of motion when the Phi axis rotates and the Theta polarisation is along the direction of motion when the Theta axis rotates.

If a certain test range utilises a different coordinate system, as defined in this Section, then it needs to be noted that the measurement results of such system need to be transformed to allow for an analysis based on the coordinate system used in this Technical Report. An example of this Measurement coordinate system is shown in Figure 1b) (X',Y',Z').

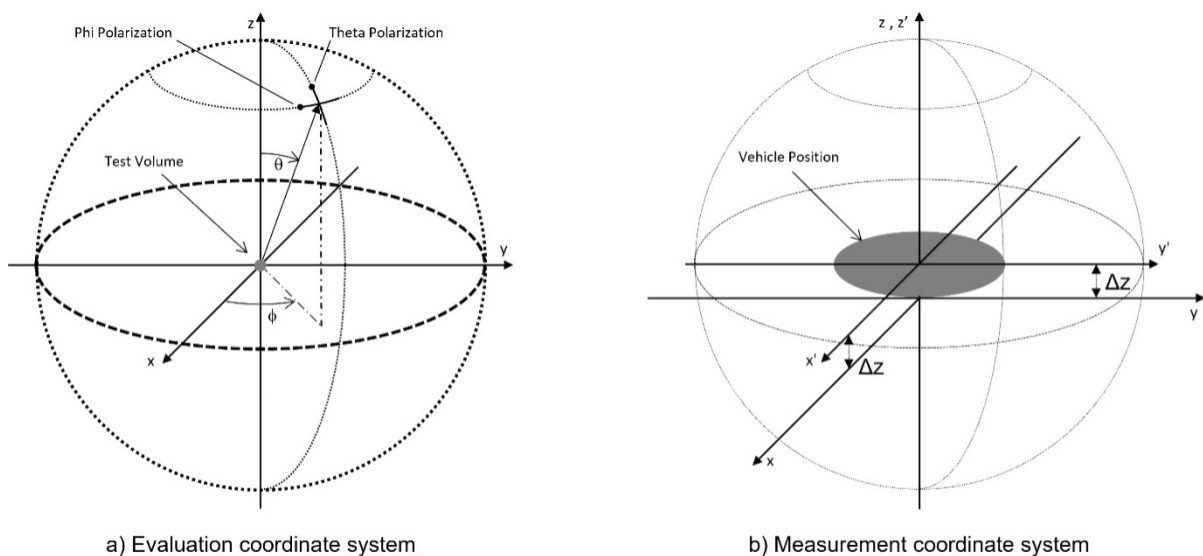

Figure 1: Coordinate systems and antenna polarisations

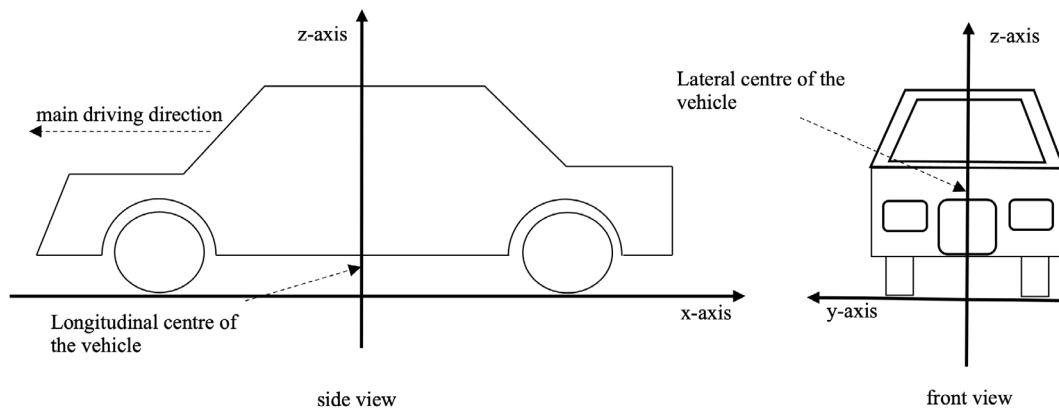

Figure 2: Vehicle's orientation within the evaluation coordinate system

1. The vehicle is positioned on the centre of the turntable or platform.
2. The origin of the coordinate system is in the centre of the turntable or platform on which the vehicle stands.
3. The z-axis aligns with the vertical axis of the vehicle to be tested.
4. The y-axis aligns with the lateral axis of the vehicle to be tested.
5. The x-axis aligns with the longitudinal axis of the vehicle to be tested (Note: in vehicular CAD systems the x-axis exits at the trunk).
6. The θ angle is defined as the angle between the z-axis and x-axis.
7. The ϕ angle is defined as the angle between the x-axis and the y-axis.

4.3 Measurement frequencies

The antenna characteristics can be expected to be frequency dependent (it can vary over the frequency). The radiation pattern of antennas is therefore typically measured in a step size between 1MHz to 10 MHz.

Communication units are typically characterised at three channels per frequency range (low-, mid- and high range). Information about these ranges, definitions of the frequency bands and channel assignments of the different wireless communication standards are given in the standards documents listed below:

GSM:	[6], clause 4.1.2, table 4.3 and table 4.4
UMTS:	[7], clause 5.1, table 5.1-1 and table 5.1-2
LTE/LTE V2X sidelink:	[3], clause 5.3 for FDD bands and clause 5.4 for TDD band
5G NR	[12], clause 5.2 and table 5.2.1-1
802.11p	[4], clause 4.2.1.1
GNSS	[9], clause 3.2

The frequencies chosen for a measurement campaign are selected based on the

supported frequency bands of all wireless communication standards of the device and on the admitted frequencies in the region the DUT is to be operated in.

When performing OTA measurements using the OTA-combinational method outlined in Section 6, the frequencies at which the antenna pattern measurements (defined in Section 5) are performed must either match those used during the OTA measurement (and vice versa), or must be obtained through a linear interpolation (ensuring that the frequencies used for the extrapolation are close enough to the target frequency to obtain accurate values).

4.4 Test volume

Since the aperture of vehicular antennas can become as wide as the vehicle itself, the maximum dimensions of the vehicle determine the size of the test volume.

The size of the test volume must be large enough to completely enclose the vehicle being tested in all possible orientations during the measurement. Examples are depicted in Figure 3 and Figure 4.

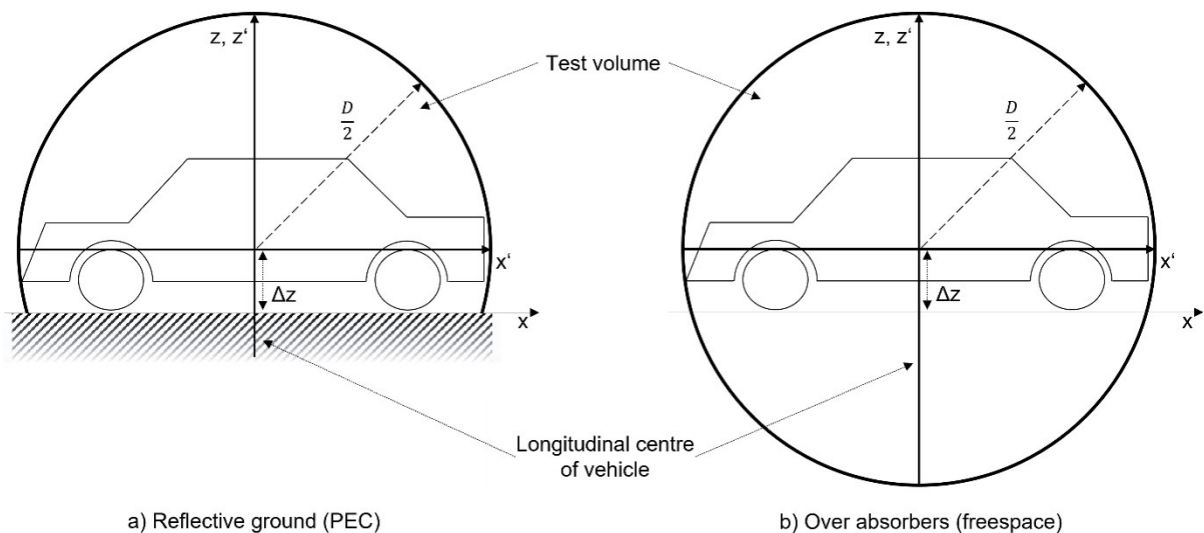

Figure 3: Size and orientation of the measurement test volume (side view)

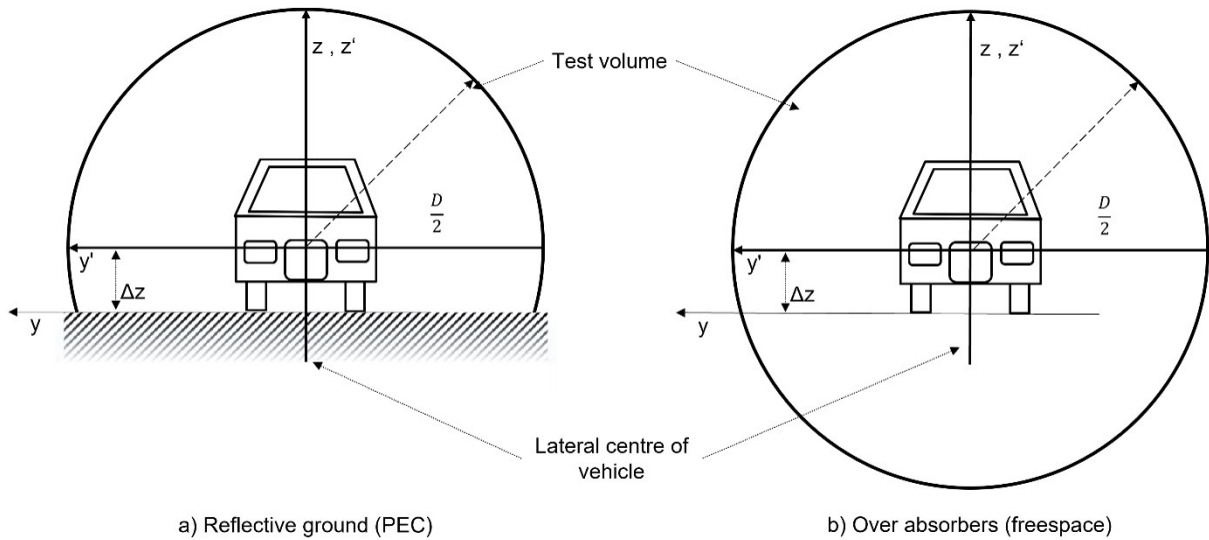

Figure 4: Size and Orientation of the measurement test volume (front view)

4.5 Environmental conditions

The antenna pattern and/or OTA measurements are performed under normal environmental conditions, as defined in TS34.121-1 [8] Annex G.2.1:

Temperature: +15°C to + 35°C

Relative humidity level: < 75 %

The voltage applied to the OBU needs to be within the normal operating range (e.g. 11V to 13.8V) as defined by the OBU manufacturer.

4.6 Test-range acceptance criteria

An acceptance criterion of the antenna test range needs to be provided. It is used to prove that the antenna test range is capable of measuring electrically large antennas (equal or greater in size than parameter D, as defined in Section 4.4) with a defined accuracy. This acceptance criteria is defined to ensure that far-field antenna parameters, such as gain values in dBi, can be measured with a certain accuracy. Prerequisites to this test range acceptance criteria are uncertainty evaluations which apply to the individual test range. For more details: 'Annex D: Uncertainty considerations' provides examples of uncertainty contributors that might be considered.

The following points have been agreed as a framework for comparing the different test methods for measuring passive and OTA vehicle-mounted antennas:

- 1) Multiple test methods (e.g. near-field, far-field)/test environments (e.g. anechoic chambers, free field test ranges) may exist for each measured parameter.

- 2) Each test method/test environment will require its own test procedure.
- 3) Definitions such as test volume size, system coordinates, and measured parameters are applicable, regardless of the test procedure.
- 4) Common maximum accepted test system uncertainty applies for all test methods/test environments addressing the measured parameters
- 5) A common way of quantifying the uncertainty result from individual test methods/test environments is used to establish 'uncertainty budgets'.
- 6) A common method needs to be used to fill in the individual test method's/ test environment's uncertainty budget
- 7) Establish a unified format of the uncertainty budget examples for each addressed test method / test environments in the form of lists of uncertainty contributions. Contributions that may be negligible with some vehicle under test (VUT) and are important to other VUT should be in this list. For each combination of measurement methods and test parameters, develop a list with measurement uncertainties.
- 8) Describe which test methods/test environments are utilised to measure VUT parameters (e.g. realised gain, gain pattern, radiated power, isotropic sensitivity). The description needs to contain information about the applicable test-range architectures and test procedures. Each uncertainty budget must contain all uncertainty terms related to the measurement, with the distribution for each term defined and the method to derive the term justified.
- 9) Example uncertainty budgets will be provided in order to demonstrate the way a budget should be defined and how a resulting measurement uncertainty is calculated. The figures used will only be examples and not applicable in general.
- 10) Each measurement type (e.g. antenna pattern measurements, OTA system measurements) may require an uncertainty budget applicable to the combination of the test environment, the VUT, the test procedure, and parameters tested. Here, the tester demonstrates that the uncertainty requirement can be fulfilled during a conformance test.

It needs to be proven and documented for each testing method that the following metrics can be measured with sufficient accuracy:

- Realised gain
- Gain pattern (realised gain in different formats)
- Partial radiated power (PRP)
- Partial isotropic sensitivity (PIS)

4.6.1 Test range acceptance method

This Section describes a test range acceptance method which has yet to be validated. It is foreseen that the described method will be optimised or replaced in a future Work Item. Until then, the method needs to be seen as an initial proposal to derive a vehicular antenna test range acceptance criteria.

The test range acceptance method shall mimic a radiation aperture of similar size to the maximum dimension of the VUT. This is accomplished by placing reference antennas, e.g. a 'monocone', horn antenna in different spatial positions on the perimeter of a verification volume which is defined as a subset of the test volume (see Section 4.4). The consideration of just a subset of the test volume is only due to practical reason.

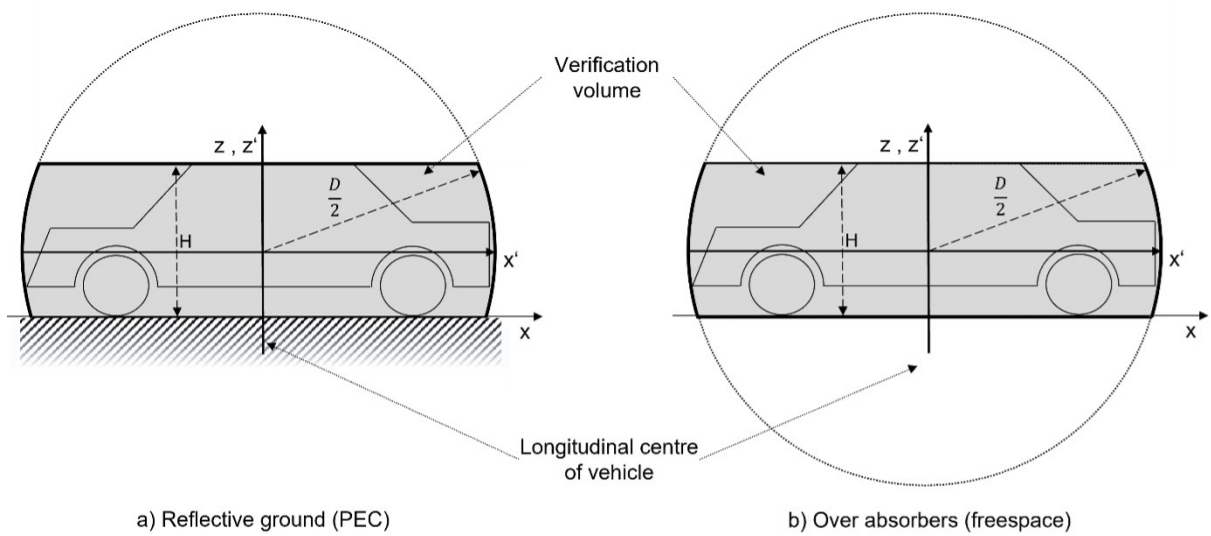

Figure 5: Size and orientation of the verification volume (side view)

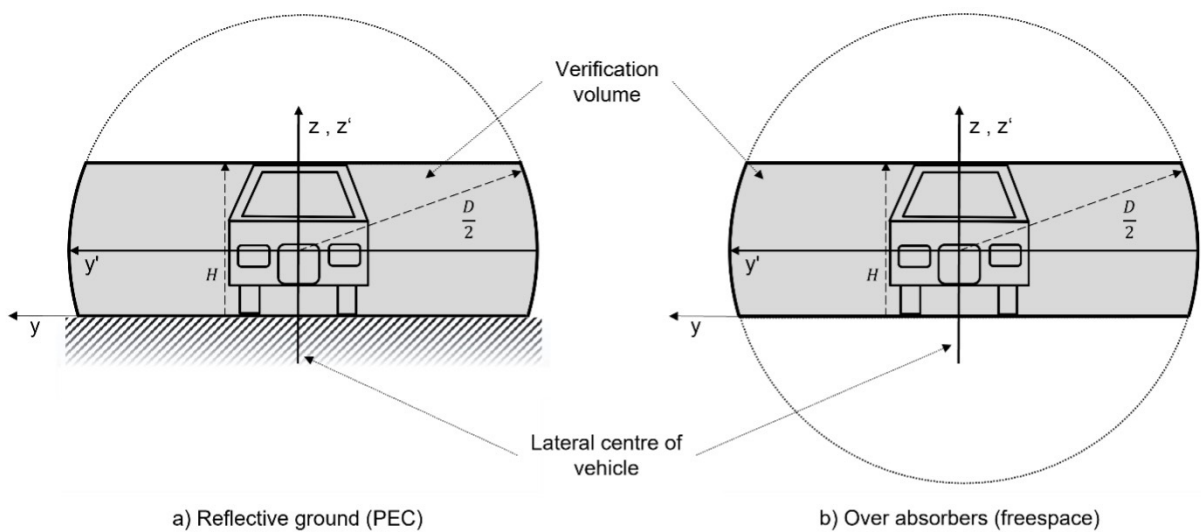

Figure 6: Size and orientation of the verification volume (front view)

Subsequently described and depicted in Figure 7 and Figure 8 is the determination of the minimum measurement positions:

1. The height of the verification volume (H) is vertically discretised into 2 elements:
 - Δh_1 or Δh_2 (lowest horizontal cut) is at the lowest feasible position of the individual test range
 - At the highest horizontal cut of the verification volume
2. The lowest and highest horizontal cut of the verification volume are discretized into 2 elements.
 - In the middle of the verification volume, along the z-axis
 - On the perimeter of the verification volume
3. The reference measurement positions are derived by the horizontal and vertical discretisation steps:
 - Highest horizontal cut
 $P_{1,2} = (x_{1,2}, y_{1,2}, H)$; $P_{2,2} = (0,0,H)$
 - Lowest horizontal cut
Note: Δh_1 and Δh_2 do not need to be at the same height.
 - a) Reflective ground (PEC)
 $P_{1,1} = (x_{1,1}, y_{1,1}, \Delta h_1)$; $P_{2,1} = (0,0,\Delta h_1)$
 - b) Over absorbers (freespace)
 $P_{1,1} = (x_{1,1}, y_{1,1}, \Delta h_2)$; $P_{2,1} = (0,0,\Delta h_2)$

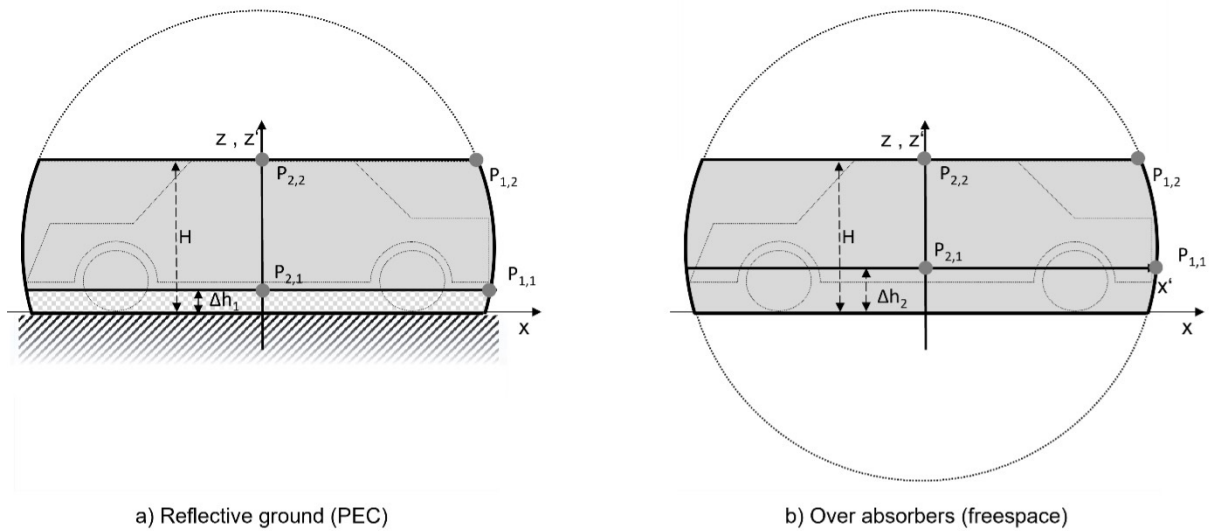

Figure 7: Measurement positions based on discretisation of the verification volume (vertical cut at $y=0$)

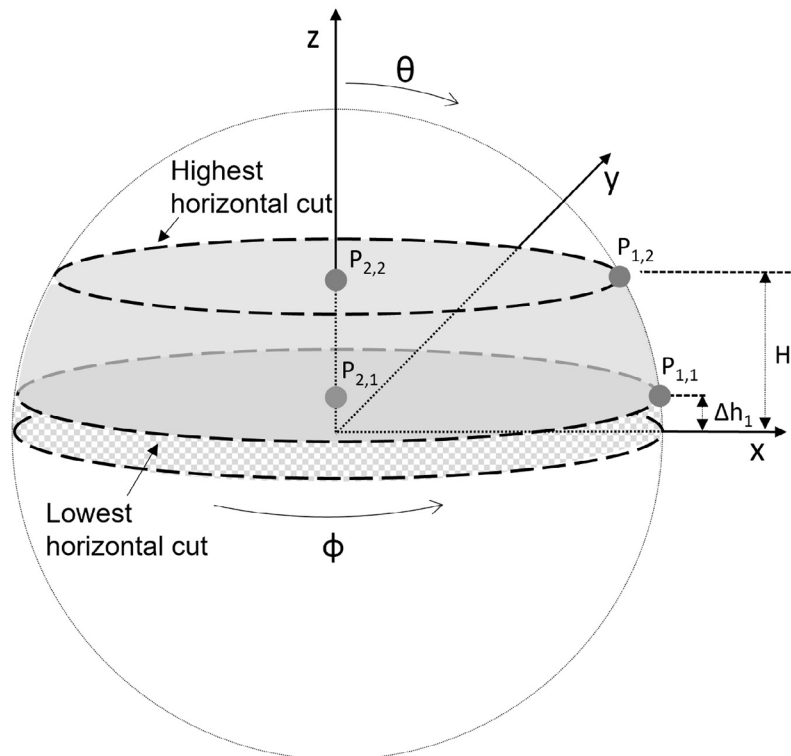

Figure 8: Measurement positions based on discretisation of the verification volume (3D-view)

As presented in Figure 8, the test range acceptance measurements should be done over the corresponding Theta and Phi ranges according to the test range criteria and the reference antenna used, described in Section 4.6.2.

Alternatively, and in order to simplify the test range acceptance measurements, the reference measurements positions can be defined in a cylinder fully containing all four reference points as depicted in Figure 9:

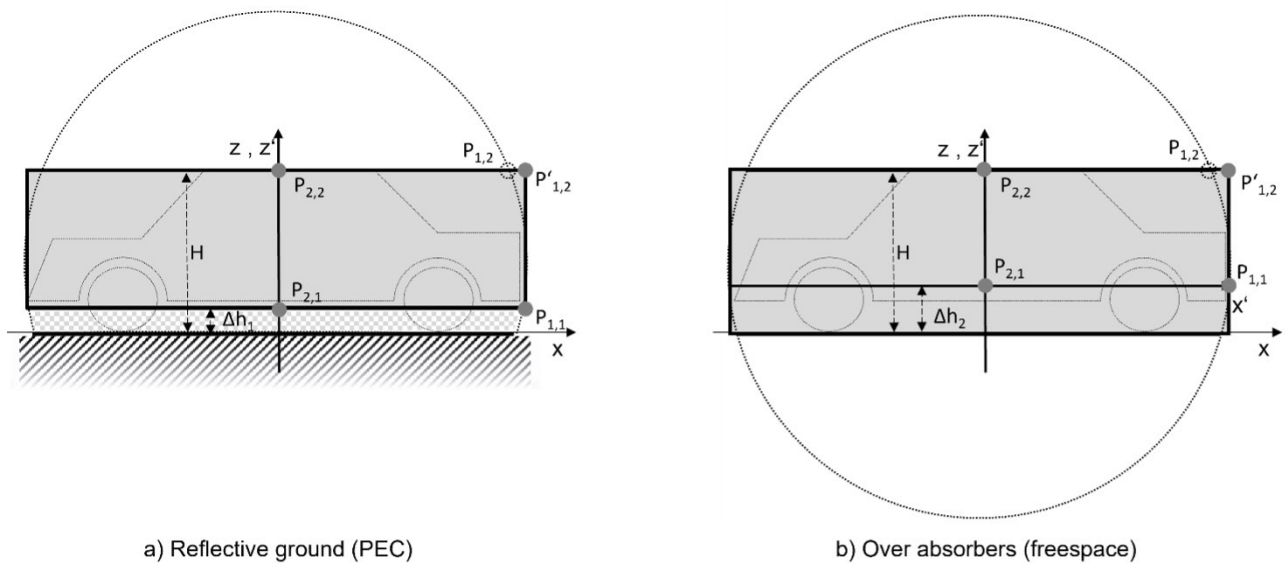

Figure 9: Alternative measurement positions based on cylindrical volume (vertical cut at $y=0$)

In this case, the reference measurement positions for the highest horizontal cut become:

$$P'_{1,2} = (x_{1,1}, y_{1,1}, H); P_{2,2} = (0,0,H)$$

Two different reference antenna types are to be used for the acceptance process:

- ▶ Monocone antenna mounted on a circular ground plane with a large enough diameter to achieve the pattern symmetry requirements in azimuth. A 1m diameter ground plane is typically used for the frequencies outlined in this test plan. A smaller diameter ground plane can be used for higher frequencies if the requirement for pattern symmetry is met.
 - Gain variation (pattern symmetry) over azimuth +/- 0.1 dB

- ▶ Horn antenna with specific frequency-dependent half power beamwidth (HPBW) requirements (boundaries between lower and upper frequencies can be linearly extrapolated)

Table 1: Horn antenna HPBW requirements

E- and H- plane	0.4GHz	7.125GHz
Min HPBW (deg)	33	23
Max HPBW (deg), applies only to measurements over reflective grounds with the main beam oriented in +x direction	66	56

4.6.2 Test range acceptance criteria

The acceptance process requires two criteria to be fulfilled.

- ▶ Criterion 1: Peak gain measurements
- ▶ Criterion 2: Partially integrated antenna gain measurements

Radiation pattern measurements of the reference antennas in the different configurations are required as listed below. All measurements shall be performed in the same way (e.g. including path loss correction) and using the same post-processing methods.

1. Reference Antenna Configurations:
2. Monopole antenna aligned along z-axis
3. Horn antenna with main beam oriented in +z direction, polarisation parallel to x-axis
4. Horn antenna with main beam oriented in +z direction, polarisation parallel to y-axis
5. Horn antenna with main beam oriented in +x direction, polarisation parallel to z-axis
6. Horn antenna with main beam oriented in +x direction, polarisation parallel to y-axis

Criterion 1:

1. Calculate the peak gain for the following:
 - Monopole in alignment with z-axis
 - Horn antenna with main beam oriented in +z-direction, polarisation parallel to x-axis
 - Horn antenna with main beam oriented in +z direction, polarisation parallel to y-axis

2. Evaluate the difference between the peak antenna gain determined above and the peak antenna gain taken from the individual reference antenna's datasheet ($\text{MaxG}_{\text{dataS}}$) or a non-accredited/accredited calibration report

$$|\text{MaxG}_{\text{ain}} - \text{MaxG}_{\text{dataS}}| \leq [2\text{dB}] \text{ (recommended)}$$

Note: Based on the tolerance associated with the peak antenna gain of the reference antenna, the lowest reference peak antenna gain (nominal peak gain – tolerance) shall be considered for criterion 1.

Criterion 2:

1. Calculate the partially integrated antenna gain, $\text{IG}_{(1-5),\text{nm}}$ according to Section 5.3.2, Table 2 'Gain pattern Theta-analysis range':
 - ▶ Analysis range 'Mobile network communication'
 - 1) Monopole in alignment with z-axis

- ▶ Analysis range 'Direct communication (V2V,V2I, V2P)'
 - 2) Horn antenna with main beam oriented in +x-direction, polarisation parallel to z-axis
 - 3) Horn antenna with main beam oriented in +x-direction, polarisation parallel to y-axis
- ▶ Analysis range 'GNSS performance'
 - 4) Horn antenna with main beam oriented in +z-direction, polarisation parallel to x-axis
 - 5) Horn antenna with main beam oriented in +z direction, polarisation parallel to y-axis

Note: The partially integrated antenna gain shall be linearly averaged.

2. For each reference configuration (i.e. reference antenna and orientation), determine the maximum difference in the partially integrated antenna gain over the five measurement points .

$$|\text{Max}(IG_{nm}) - \text{Min}(IG_{nm})| \leq [2\text{dB}] \text{ (recommended)}$$

The test range acceptance criteria needs to be applied to all frequencies used in the later antenna test campaigns. For practical reasons two frequency step sizes are recommended:

1. Frequency < 1GHz → Test one frequency every 100MHz
2. Frequency > 1GHz → Test one frequency every 200MHz

5 Antenna pattern measurements

Antenna pattern measurements are also often referred to as passive antenna measurements. Typically, there is no communication protocol involved in this measurement.

The key parameters are the antenna radiation pattern, antenna directivity, antenna impedance match and antenna efficiency. These parameters are typically collected in free-space antenna test ranges or full anechoic chambers. Antenna radiation pattern are based on the realised antenna gain which is defined by as follows:

'Realised Gain (dBi)= Directivity (dBi) – Mismatch Loss (dB) – Efficiency Loss (dB)' [2]
Section 9.1.5.3

Figure 10 depicts the plot of the antenna gain on the horizon (i.e. horizontal plane at theta = 90°)

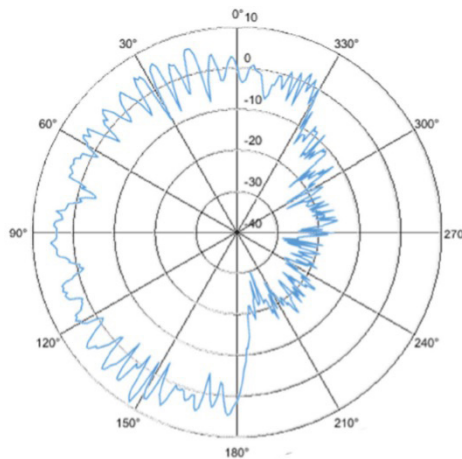

Figure 10: Example of an antenna radiation pattern [dB]

5.1 Measurement methodologies/ definitions

Figure 11 depicts a block diagram of a typical measurement system for antenna pattern measurements. It consists of a probe antenna system which allows measurements in different elevation angles (θ). The antenna under test (AUT) is mounted on its final installation location on the vehicle. The vehicle under test is placed on an azimuth positioner which allows different orientations towards the probe antenna (ϕ). The AUT should be directly connected to the vector network analyser (VNA) via a measurement path (bold line). Alternatively, the measurement path to the VNA can be connected to the vehicle harness. In this case, the losses of the vehicle harness contribute to the antenna key parameters such as efficiency and antenna gain. This needs to be clearly indicated and recorded to allow for a proper processing of the measurement results.

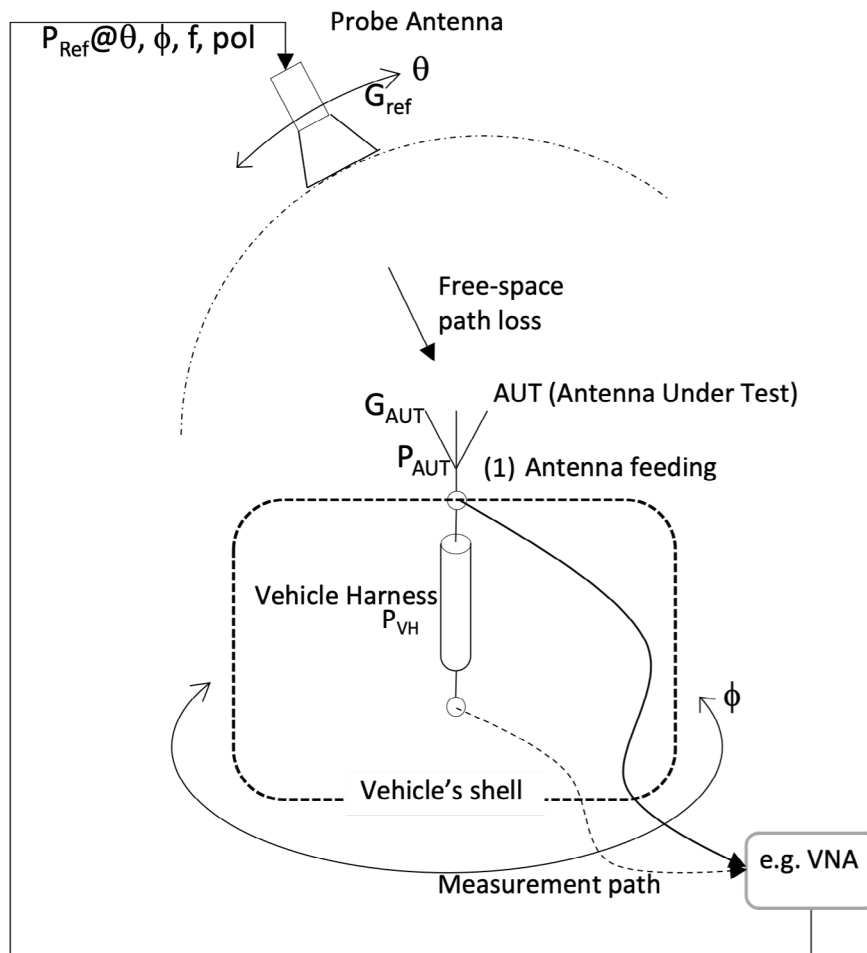

Figure 11: Antenna pattern measurement setup

The measurement system setup in Figure 11 can be implemented by setting the probe in far-field or near-field. In terms of range length (distance between probe and VUT) this means:

- Far-field criteria: $R > \frac{2D^2}{\lambda}$, with D as defined in 4.1
- Near-field criteria: The measurement distance shall be adequate to ensure that the measurements are performed in the radiating near-field of both the VUT and measurement antenna and not in the reactive near-field. A minimum distance of 2λ will be adequate in most cases to achieve the required distance, but care must be taken since this distance is contingent on the measurement setup and test range.

The VUT radiation characteristics are generally defined in far-field.

5.1.1 Measurement equipment

- ▶ Spherical positioning system (to allow accurate positioning in θ and ϕ dimensions). Alternatively:
 - Multiple probe antennas can be placed along an arch in the vertical plane and electronically switched in order to get the full 3D radiation pattern
 - Other scan systems can be used (e.g. cylindrical, planar, etc.) in the event a transformation of the results to spherical coordinates is possible with sufficient accuracy (only spherical coordinates will be used in this TR)
- ▶ Probe antenna(s), linearly polarisation (horizontal/vertical), for near-field measurements the response(s) need to be known
- ▶ Measurement path, which may include components such as (but not limited to) cables, switches, amplifiers...
- ▶ Network analyser or signal generator/measurement receiver

5.1.2 Near-field test method

The near-field measurement technique involves measuring amplitude and phase (with a stable phase reference) of at least two orthogonal components of the electromagnetic field radiated at the AUT (in this context VUT), on a specific surface such as a planar, cylindrical or spherical surface. Each of the near-field test methods can be implemented by one or more mechanical rotations of the probe and/or device under test, as shown in Figure 12. One or more mechanical movements can be substituted by a probe array. All scanning methods require an radio frequency (RF) transmit and receive system equipped with an automated scanning, data collection and control system, and computerised analysis ability.

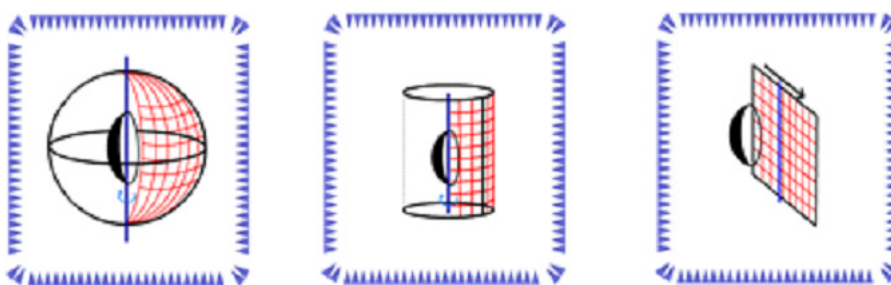

Figure 12: Probe/Scanner near-field system

The radiated near-field is measured when either the VUT is transmitting or receiving the signal coming from an external source. Near-field or NF measurement techniques imply the use of mathematical processing, known as near-field to far-field or FF transformation in order to compute the antenna characteristics in the far-field [1][5]. NF to FF transformation techniques are applications of the Huygens-Fresnel principle, or

of the equivalence theorem. Various implementations exist which involve, for example, field expansions in cylindrical or spherical harmonics, plane-waves or equivalent current reconstructions. Specific care has to be taken to ensure accurate use of these methods, such as fulfilling known criteria for the near-field sampling criteria. [5]

5.1.3 Far-field test method

The far-field measurement technique involves measuring the amplitude and phase for specified polarisations and frequencies of the signal at the VUT, on the surface of a hemisphere. The distance between the source antenna and the VUT should be sufficient to satisfy the far-field distance criterion. The spatial resolution in both the θ - and ϕ - directions are dictated by the desired far-field quantities called for by the particular wireless system. Unlike the near-field measurement technique, no further transformations are required on this data set.

The radiation field is sampled on a hemisphere surrounding the VUT (whole car) in the far field range. The 3D far-field is measured when the VUT is either transmitting or receiving the signal to or from an external source.

5.1.4 Path loss calibration

A path loss calibration must be performed in order to have correctly scaled measurement results (dBi, EIRP, EIS). The compensation includes the free-space path loss, the gain of the measurement antenna and the total loss of the measurement path (which may include gain from amplifiers).

The calibration of the measurement range needs to be performed for all test cases and frequencies. It must include a reference antenna with known gain over the frequency range of the measurement.

One of the measurement uncertainty terms which must be included in the overall calculation is 'mismatch'. Using an attenuator during the calibration process will reduce this contribution.

One method that can be used to determine the path loss, and from this the antenna gain, is given in [1], 8.4 Gain-Transfer Measurement.

The validity of the path loss calibration needs to be proven.

This document is not intended to describe complete calibration procedures. Rather, it alerts the reader of the need to follow the appropriate procedures of the individual test-ranges to measure antenna gain with a certain accuracy. According to the specific test-range type, near-field or far-field, differences in the calibration methods will occur.

Methods for calibrating FF and NF test-ranges are described in [5].

5.1.5 Uncertainty considerations

An analysis of the measurement uncertainty needs to be performed and documented. Examples of uncertainty analysis for the respective measurements can be found in Annex D: Uncertainty considerations.

5.2 Measurement procedures

The measurement procedures of the individual test ranges can differ. Therefore this section describes the measurement procedures of near-field and far-field test ranges only generally.

5.2.1 Near-field test procedures

The testing procedure mainly consists of the following steps:

1. Measure the radiation pattern of two orthogonal components of the electric and/or magnetic field (typically Theta (θ) and Phi (ϕ) components of the electric field, in both amplitude and phase) of the near-field radiation by the AUT:
 - a. VUT feeding: a classical implementation uses a continuous wave (CW) source to feed the antenna. Other approaches can allow the use of modulated signal by employing, for instance, phase-coherent acquisition of signals and comparing them to a phase reference at a fixed position with respect to the VUT.
 - b. Scanning surface: the scanning surface encompasses the complete VUT structure, and the distance between the probe and the VUT should be sufficient to minimise errors due to coupling. Because of limitations in practical implementations, it is generally not possible to measure samples across a fully closed surface around the VUT. Such limitations are known to generate 'truncation errors' and algorithms to mitigate these effects might be applied.
2. Compute the near-field to far-field transformation:
 - a. During this post-processing step, the gain calibration is applied to the near-field measured data.
 - b. The near-field to far-field transformation is applied to the near-field measured radiation pattern in order to compute the far-field radiation pattern. It may be performed by expanding the measured near-field over a set of orthogonal basis functions, or by reconstructing equivalent source currents over a defined surface surrounding the VUT.

5.2.2 Far-field test procedures

The testing procedure mainly consists of the following steps:

1. Range calibration: measure the antenna range system losses for a CW signal with the appropriate polarisation power level at the required frequency points.
2. VUT data collection: measure the radiation pattern of the far-field radiation by the VUT for the desired polarisation, frequencies and spatial points over a spherical surface.

3. Far-field radiation pattern characteristics determination: determine the desired far field radiation pattern characteristics from the data collected in steps 1 and 2 above.

5.2.3 Measuring angle range definition

The azimuth and elevation angle ranges and angular step-size used for antenna pattern measurement must be well chosen to enable accurate analyses of the angle ranges of interest in later stages of the process. These angle ranges may be test-range dependent and need to account for the specific type, near-field or far-field. It needs to be ensured that the measurement results can be properly analysed in the angle ranges, as defined in Section 5.3.2.

For measurements on far-field test ranges, at least the analysis angle ranges (as defined in Section 5.3.2) need to be used as measurement range unless electromagnetic fields reconstruction techniques are used.

5.2.4 Antenna gain measurements

A detailed description of antenna gain measurements is given in [1], 8.4 Gain-Transfer Measurement.

The results of the gain measurement may be used to get values for the radiated power and isotropic sensitivity in combination with the OTA measurements of the complete vehicle. To enable such combination of results, the antenna gain needs to be measured at the same frequencies as used later in the process. Therefore frequencies in the low-, mid- and high range of each frequency band supported by the OBU connected to the antenna should be considered. Here, the RX and TX frequencies of FDD bands (see abbreviations) should be measured. Section 4.3 refers to external standards defining the low-, mid- and high range of each frequency band.

For further processing the measurement results, the environmental conditions, as defined in Section 4.5, should be recorded.

5.2.5 Vehicles implementing transmit and/or receive antenna diversity

The usage of transmit diversity, or transmit antenna switching, and/or receiver diversity (at least two ports) is a very common implementation for cellular communications and requires very special handling in radiated measurements.

When the results of gain measurements are used to obtain the radiated power and isotropic sensitivity, in combination with the OTA measurements of the complete vehicle, gain pattern measurements are to be performed separately per antenna, and the results will be further processed according to Section 6.3.

5.3 Result analysis

This Section describes how the antenna gain is derived from the measurement results. Further, the radiation characteristics of vehicular communication antenna are explained. These characteristics imply the evaluation of certain angle combinations and ranges.

5.3.1 Vehicular communication characteristics

The various communication technologies found in vehicles, such as mobile communication, direct communication (V2V, V2I, V2P) and satellite communication, have different service characteristics.

As indicated in Figure 13 and Figure 14, the individual communication counterparts can have different orientations towards the vehicle. This needs to be accounted for by directing the dominant radiation of the vehicular antennas according to the individual service demands.

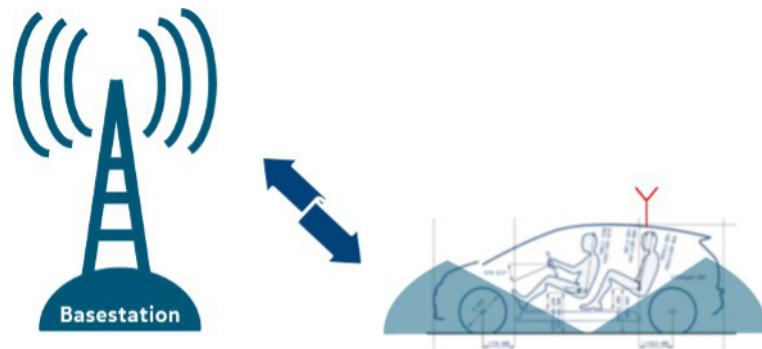

Figure 13: Characteristic of a mobile communication

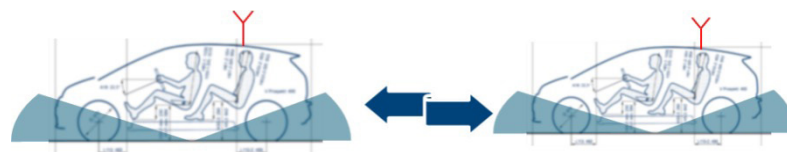

Figure 14: Characteristic of a vehicle-to-vehicle communication

To evaluate the characteristic of the antenna for the corresponding communication technologies, different elevation ranges may be analysed (as depicted in Figure 15).

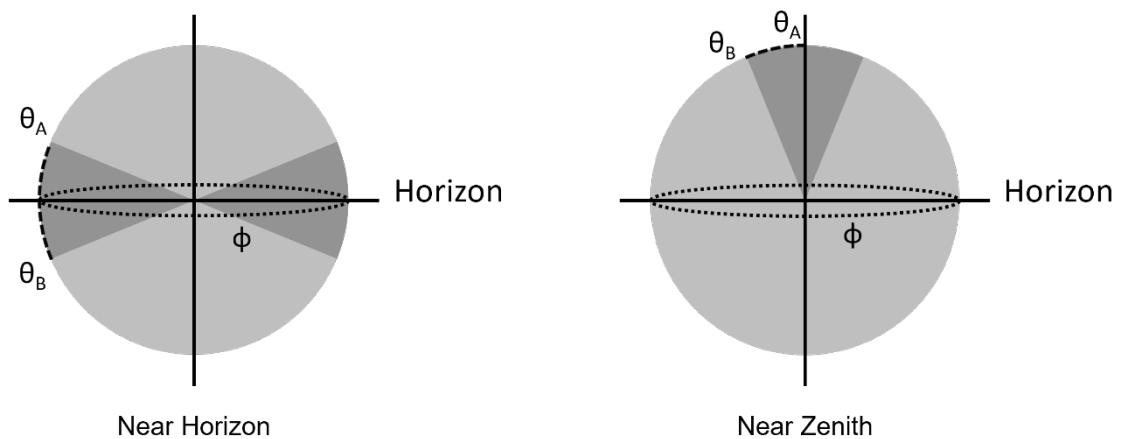

Figure 15: Examples of elevation angle analysis ranges

5.3.2 Analysis angle range definition

The analysis angle range is based on the coordinate system defined in Section 4.2.

To analyse vehicular antenna characteristics only far-field data is of interest. In Section 4.1 different test environments with different ground material are defined. The ground material used during the measurement process also affects the far-field data, therefore the analysis angle range needs to be separated by the ground material.

Ground material such as metal reflects electromagnetic waves. Parts of the reflected electromagnetic energy will be measured along with the directly radiated electromagnetic energy. Therefore the measured energy in the upper hemisphere will be larger compared to the measurements over non-reflective ground materials such as those of full anechoic chambers.

To be able to compare the measurement results of reflective and non-reflective grounds, the elevation angle range needs to be adjusted according to the ground material. The principle to mirror the elevation range at the horizon is a good approach to allow a comparison of averaged metrics. For peak metrics, the mirroring principle can only be applied if an additional uncertainty factor is introduced.

In cases when the elevation angle range exceeds the antenna test range's capabilities, it is appropriate to utilise mathematical tools to reconstruct the electromagnetic fields at large elevation. The contribution of such reconstructions to the measurement uncertainty needs to be minimised and considered in the analysis. Further, the acceptance criteria defined in Section 4.6 needs to be fulfilled.

Table 2: Gain pattern Theta-analysis range

Service	Reflective ground material			Absorbing ground material		
	θ_A (deg)	θ_B (deg)	Max. $\Delta\theta$ (deg)	θ_A (deg)	θ_B (deg)	Max. $\Delta\theta$ (deg)
Mobile network communication	60	90	$\Delta\theta(f)$	60	120	$\Delta\theta(f)$
Direct communication (V2V, V2I, V2P)	80	90	$\Delta\theta(f)$	80	100	$\Delta\theta(f)$
GNSS performance	0	60	$\Delta\theta(f)$	0	60	$\Delta\theta(f)$
GNSS suppression	70	90		70	110	
Service independent – reflective peak analysis	0	90	$\Delta\theta(f)$	1)	1)	1)
Service independent – absorbing peak analysis	1)	1)	1)	0	180 ²⁾	$\Delta\theta(f)$

Note 1: For peak analysis the mirroring principle can only be applied if an additional uncertainty factor is considered.

Note 2: Details on θ_B elevations range refer to Chapter 5.3.5.

Independent of the services and ground material an identical ϕ range of 360° is considered.

Table 3: Gain pattern Phi-analysis range

ϕ_A (deg)	ϕ_B (deg)	Max. $\Delta\phi$ (deg)
0	360- $\Delta\phi$	$\Delta\phi(f)$

The angular step size in azimuth and horizontal direction is frequency dependant, following this relation:

$$\Delta\theta(f) \leq \frac{c_0}{f \cdot D} \cdot \frac{180^\circ}{\pi} \quad \text{Equation 3}$$

$$\Delta\phi(f) \leq \frac{c_0}{f \cdot D} \cdot \frac{180^\circ}{\pi} \quad \text{Equation 4}$$

f represents the frequency at which the measurement is to be performed,

c_0 is the speed of light in vacuum,

D represents the size of the antenna aperture, which is equal to the maximal dimension of the vehicle under test (refer to Section 4.4).

Table 4 shows the relation between the azimuthal (Phi) and horizontal (Theta) step size with respect to the measurement frequency for an aperture size of 3m.

Table 4: Azimuthal and horizontal step size at selected frequencies

f (MHz)	Max. $\Delta\theta$ (f), Max. $\Delta\phi$ (f) (deg)
600	9.5
700	8.2
800	7.2
900	6.4
1800	3.2
1900	3
2000	2.9
2100	2.7
2200	2.6
2400	2.4
2500	2.3
2600	2.2
2700	2.1
2800	2
3400	1.7
3500	1.6
3600	1.6
3700	1.5
3800	1.5
3900	1.5
5400	1.1
5500	1
5700	1
5800	1
5900	1

5.3.3 Gain normalisation

In [1] and [5], several methods are listed to determine the antenna gain at antenna measurement facilities.

As one example, the gain substitution method is explained here to calculate the gain of the antenna under test (AUT):

The power response of an AUT is measured against the power response of a reference antenna (e.g. standard gain horn). The known response curves of the calibrated reference antenna are used to calibrate the AUT response in dBi. This is the standard calibration by substitution method. The known response curves are derived during a calibration process of the reference antenna and are typically provided along with the reference antenna.

The calculation of gain is:

$$G_{\text{AUT,pol}}(f, \theta, \phi) = G_{\text{Ref,pol}}(f) + P_{\text{AUT,pol}}(f, \theta, \phi) - P_{\text{Ref,pol}}(f) \quad \text{Equation 5}$$

where,

- $G_{AUT,pol}(f, \theta, \phi)$ is the computed gain of the AUT using the gain substitution method,
 $G_{Ref,pol}(f)$ is the absolute gain of the reference antenna provided by the manufacturer,
 $P_{AUT,pol}(f, \theta, \phi)$ is the received complex forward transmission gain of the AUT,
 $P_{Ref,pol}(f)$ is the received complex forward transmission gain of the reference antenna,
 f is the frequency at which the gain is computed,
 θ is the elevation angle of the AUT,
 ϕ is the azimuth angle of the AUT, and
 pol is the polarisation of the AUT.

The gain in Equation 5 can be calculated for an arbitrary polarisation by appropriately computing the received complex forward transmission for the appropriate polarisation. The complex forward transmission gain response for vertical linear polarisation (VLP), horizontal linear polarisation (HLP), left-hand circular polarisation (LHCP) and right-hand circular polarisation (RHCP) are depicted in Equations 6-9, respectively.

$$P_{VLP}(f, \theta, \phi) = P_{VLP}(f, \theta, \phi) \quad \text{Equation 6}$$

$$P_{HLP}(f, \theta, \phi) = P_{HLP}(f, \theta, \phi) \quad \text{Equation 7}$$

$$P_{LHCP}(f, \theta, \phi) = P_{VLP}(f, \theta, \phi) + j \cdot P_{HLP}(f, \theta, \phi) \quad \text{Equation 8}$$

$$P_{RHCP}(f, \theta, \phi) = P_{VLP}(f, \theta, \phi) - j \cdot P_{HLP}(f, \theta, \phi) \quad \text{Equation 9}$$

Calculation of circular gain requires the AUT and the reference antenna to be stimulated by two orthogonal linear polarisations. Once the complex forward transmission gain responses are converted to the same polarisation, then Equation 5 can be applied to compute the gain of the AUT. The two orthogonal polarisation measurements are measured. Alternatively, a CW source can be directly radiated to get the simulated response from the reference antenna.

The ideally computed complex forward transmission gain response of the reference antenna at bore site vs. azimuth angle for VLP, HLP, RHCP and LHCP is illustrated in Figure 16. The complex forward transmission gain response of the AUT at any spatial point for VLP, HLP, RHCP and LHCP is calculated. Equation 5 is utilized to compute the gain of the AUT for the desired polarisation after performing the appropriate calculation from Equations 5-9.

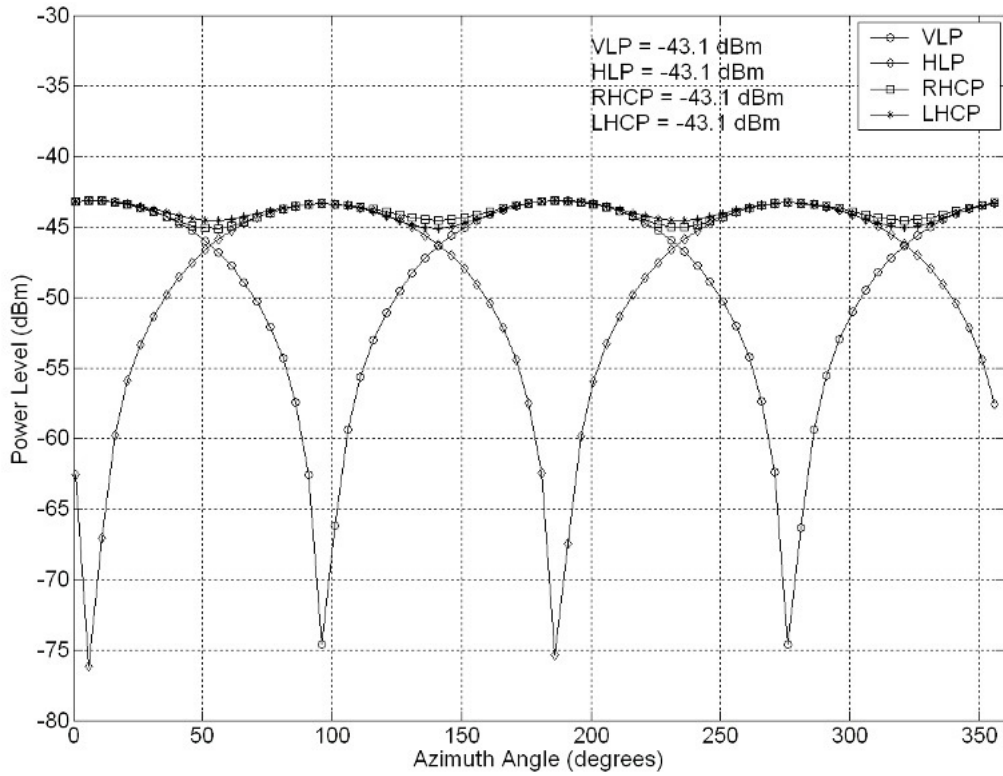

Figure 16: Ideally computed received power level response of a standard gain horn at boresight vs. azimuth angle for VLP, HLP, RHCP and LHCP

5.3.4 Average gain

This Section describes how to calculate an average antenna gain over a certain angular range. The average gain will also be used to derive a convergence criteria of the peak gain analysis, as described in Section 5.3.5.

It needs to be noted that all angular values used in this Section have to be converted into radian following this conversion scheme:

$$\theta[\text{rad}] = \theta [^\circ] \cdot \frac{\pi}{180^\circ} \quad \text{Equation 10}$$

$$\phi[\text{rad}] = \phi [^\circ] \cdot \frac{\pi}{180^\circ} \quad \text{Equation 11}$$

Based on the analysis angle range defined in Section 5.3.2, the elevation range is divided into p Theta-intervals:

$$p = \frac{\theta_B - \theta_A}{\Delta\theta} + 1 \quad \text{Equation 12}$$

Similarly, the azimuth range is divided into q Phi-intervals:

$$q = \frac{\phi_B - \phi_A}{\Delta\phi} + 1 \quad \text{Equation 13}$$

$\Delta\theta$ and $\Delta\phi$ need to meet these conditions:

$$\Delta\theta \leq \frac{c_0}{f \cdot D} \quad \text{Equation 14}$$

$$\Delta\phi \leq \frac{c_0}{f \cdot D} \quad \text{Equation 15}$$

As indicated in Section 5.3.2, there is no service-dependant separation of the azimuth range, therefore horizontal cuts can be introduced. Figure 17 depicts an example of p equidistant, horizontal conical cuts over a certain horizontal elevation range.

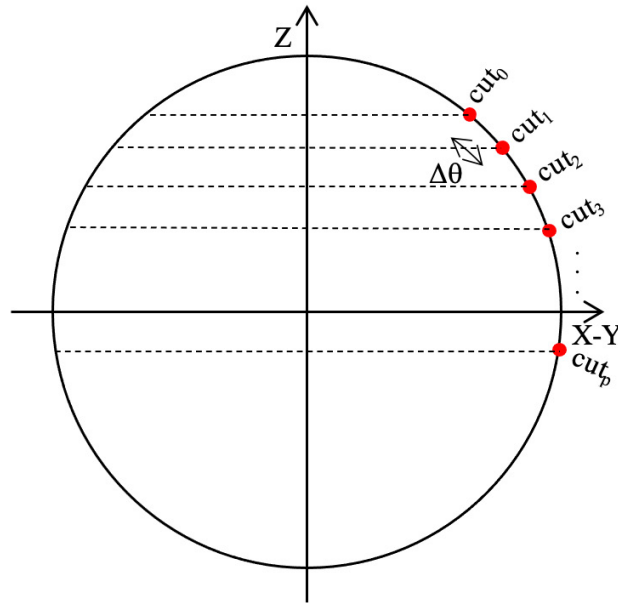

Figure 17: Examples of horizontal cuts (cut)

If the antenna gain is partially analysed over a range $\theta = [\theta_A, \theta_B]$ and the complete azimuth range is normalised to certain cuts of an ideal radiator, then the average gain can be calculated as follows:

$$\text{AvgGain}_{cut} = \frac{1}{q \cdot \left(\frac{\sin \theta_0 + \sin \theta_p}{2} + \sum_{i=1}^{p-1} \sin \theta_i \right)} \cdot \left(\frac{\text{cut}_0 + \text{cut}_p}{2} + \sum_{i=1}^{p-1} \text{cut}_i \right) \quad \text{Equation 16}$$

With

$$\text{cut}_i = \sum_{j=0}^{q-1} [G_{\text{AUT},\theta}(\theta_i, \phi_j) + G_{\text{AUT},\phi}(\theta_i, \phi_j)] \cdot \sin \theta_i \quad \text{Equation 17}$$

representing the weighted sum of each conical cut.

Typically, the antenna gain is partially analysed over a Theta range $[\theta_A, \theta_B]$ and the complete azimuth range normalised to an ideal radiator. Then the average gain is calculated by

$$\text{AvgGain} = \frac{\Delta\theta \cdot \Delta\phi}{4\pi} \cdot \left(\frac{\text{cut}_0 + \text{cut}_p}{2} + \sum_{i=1}^{p-1} \text{cut}_i \right) \quad \text{Equation 18}$$

with

$$\text{cut}_i = \sum_{j=0}^{q-1} [G_{AUT,\theta}(\theta_i, \phi_j) + G_{AUT,\phi}(\theta_i, \phi_j)] \cdot \sin \theta_i \quad \text{Equation 19}$$

5.3.5 Peak gain

The peak gain can be evaluated either for the service-independent peak analysis ranges, as defined in Section 5.3.2 (Table 2), or for each other service-dependent analysis angle range. In the latter case, it should be ensured that the AUT's main beam is within the corresponding analysis angular range.

The service-independent absorbing peak analysis range defines a θ_b of 180°. It should be noted that the actual measurement range underlies technical limitations and that mathematical tools may be utilised to extend the analysis range beyond the measurement range (angular extrapolation). If θ_b is approaching 180°, the uncertainty introduced by the utilisation of such mathematical tools may become unacceptable. Therefore, it is proposed to stop the angular extrapolation process if no further changes to the average gain are observed during the measurement/extrapolation process. This criteria demand that the average gain is continuously calculated during the measurement/extrapolation process.

The peak gain is evaluated based on the normalised gain derived in Section 5.3.3:

$$\text{PeakGain} = \text{Max}(G_{AUT}(\theta, \phi)) \quad \text{Equation 20}$$

with

$$G_{AUT}(\theta, \phi) = G_{AUT,\theta}(\theta, \phi) + G_{AUT,\phi}(\theta, \phi) \quad \text{Equation 21}$$

6 OTA system measurements

The purpose of this Section is to describe procedures to evaluate the behaviour of the complete communication system, which in this context includes the vehicle's antenna, all vehicular harness and connections, as well as the OBU. The measurements are done over the air with an active communication link between the radio communication tester and the OBU.

Two methodologies to determine the OTA system performance of vehicular communications systems will be described:

- ▶ OTA-conventional method: measurements only with an active communication link.
- ▶ OTA-combinational method: combination of passive antenna gain measurements and measurements with an active communication link.

OTA system measurements can be very time consuming, specifically the determination of the receiver performance. The OTA-combinational approach is considered to save measurement time by combining the results of the antenna pattern (antenna gain) measurements with selected OTA measurements.

Further, key metrics of the OTA system's performance covering different service characteristics of various communication technologies in vehicles, such as e.g. mobile communication, direct communication (V2V, V2I, V2P), and satellite communication, are introduced in Section 6.3.1.

6.1 Measurement methodologies/ definitions

In order to avoid interference with external communication systems (e.g. mobile networks), OTA measurements are recommended only in anechoic or shielded environments, as described in Section 4.1 a) and b).

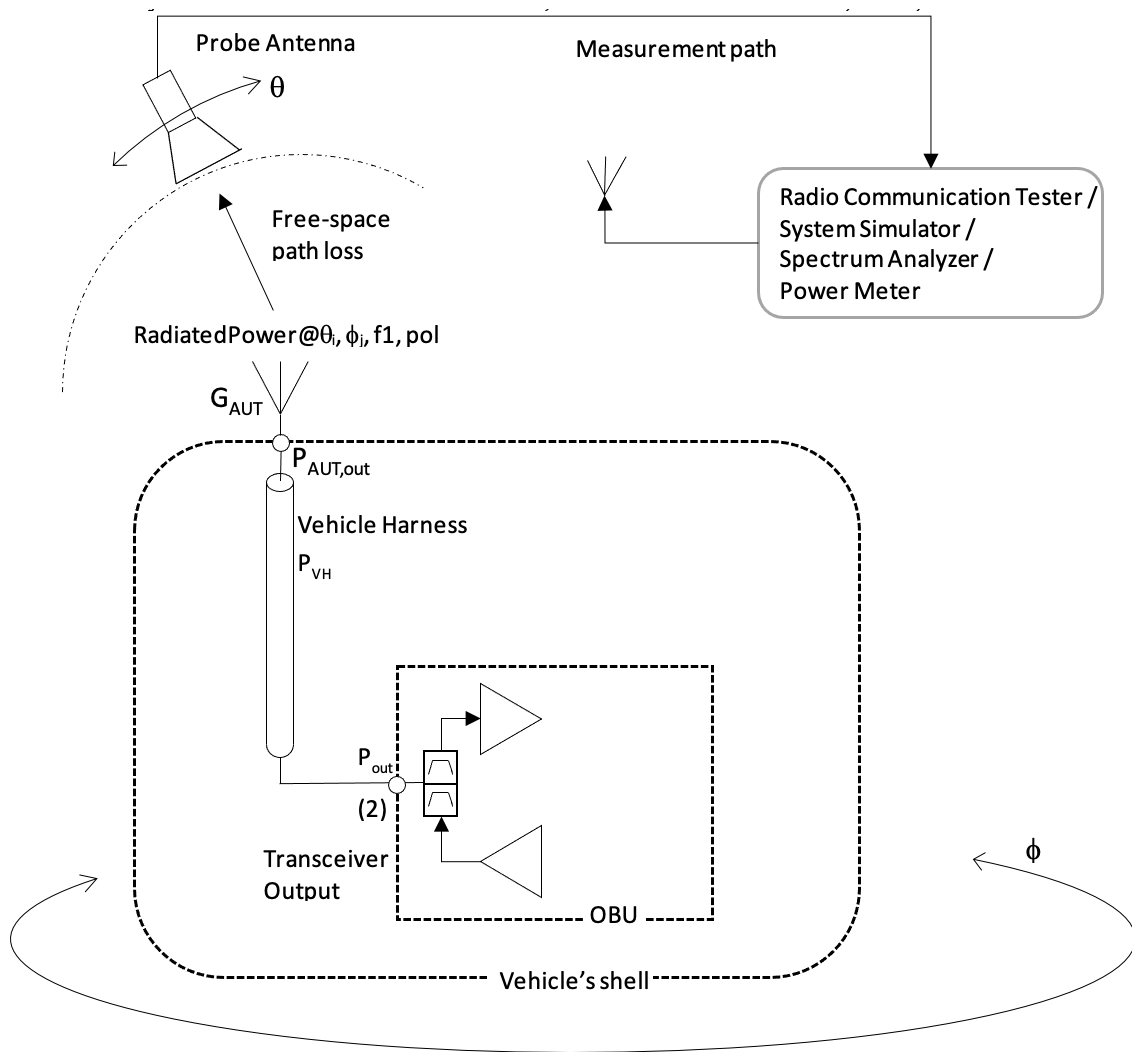

Figure 18: OTA measurement setup, radiated power

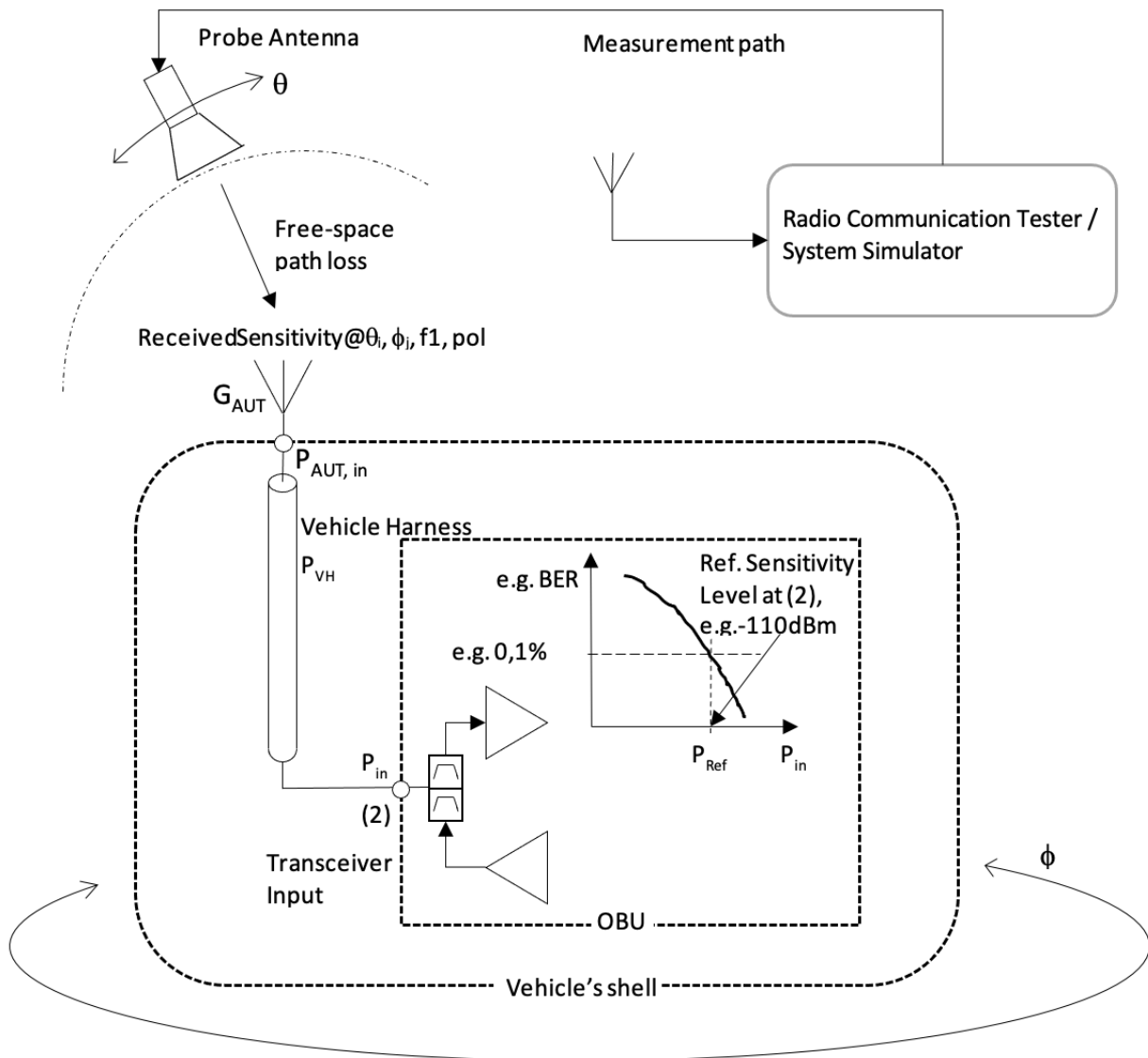

Figure 19: OTA measurement setup, radiated sensitivity

6.1.1 Measurement equipment

- ▶ Spherical positioning system (to allow accurate positioning in θ and ϕ dimensions).
Alternatively:
 - Multiple probe antennas can be placed along an arch in the vertical plane and electronically switched to get the full 3D radiation pattern.
 - Other scan systems can be used (e.g. cylindrical, planar, etc.) in case a transformation of the results to spherical coordinates is possible with sufficient accuracy. In this document only spherical coordinates will be used.
- ▶ Probe antenna(s), linearly polarisation (horizontal/vertical).
- ▶ Link antenna(s) (if required for assuring a stable wireless link).
- ▶ Measurement path: this might include components such as (but not limited to) cables, switches, amplifiers, etc.
- ▶ Radio communication tester/system simulator (emulating communication counterparts, e.g. mobile networks, satellites, RSUs/vehicles), spectrum analyser or power meters may be used for power measurements.

6.1.2 Calibration

See 5.1.4

6.1.3 Uncertainty considerations

An analysis of the measurement uncertainty needs to be carried out and documented. Examples of uncertainty analysis and the evaluation of measurement uncertainty from radiated power and isotropic sensitivity measurements can be found in [12] Annex A.4.

6.2 Measurement procedures

Procedures explained in the next Sections need to be executed within the same test environment conditions as those defined in Section 4.5.

6.2.1 Measuring angle range definition, OTA-conventional method

The azimuth and elevation angle ranges and angular step size used for the OTA measurement must be well chosen to allow in the later process for an accurate analysis of the angle ranges of interest, as defined in Section 6.3.2. The measuring angle ranges may be test-range dependent and need to account for the specific test-range type. The acceptance criteria, as defined in Section 4.6, needs to be fulfilled.

6.2.2 Measuring angle range definition, OTA-combinational method

Refer to Section 5.2.3 for azimuth/elevation angle ranges and angular step size used for the OTA measurements. The measuring angle ranges may be test-range dependent and need to account for the specific test-range type. The acceptance criteria, as defined in Section 4.6, needs to be fulfilled.

6.2.2.1 Measuring angles at selected combinations

If a combination of results, according to Section 6.3.3, is to be performed then it is important to use the same vehicle- vehicular antenna combination for which antenna pattern results are available. Similarly, it is important for the resulting combination to place the vehicle in the same position as for the antenna pattern measurement, and to refer to the same coordinate system.

OTA measurements will only be performed at certain combinations of θ - and ϕ -angles. The measurements will be processed using the results of the antenna-pattern measurements, therefore it should be ensured that only θ - and ϕ -angles combinations are used for which antenna pattern results are available.

It is recommended to perform at least five measurements at five different θ - and ϕ -angle combinations, to reduce the statistical error. To further minimise the measurement uncertainty, it is also important to choose OTA measurement points (θ - and ϕ -angle combinations) which are within the desired analysis range, as defined in Section 6.3.2, and which are at or close to the peak gain point for each frequency.

6.2.3 OTA radiated power

This Section describes how to derive the radiated power of individual communication technologies at any θ - and ϕ -angle combinations, regardless of the method used (see Sections 6.2.1 and 6.2.2). The measured results derived in Section 6.3 are based on the EIRP, a measure of the radiated power in the far-field. Additional calculations may be needed to provide final EIRP values. The appropriate calculations depend on the individual test-range type and measurement method used to determine the radiated power. Such specific calculations are not part of this document.

In many cases, a direct far-field measurement of the EIRP is not possible due to the large test-range length required for testing in far-field conditions, as described in Section 4.1. In such cases, EIRP can be calculated from measurements in the near-field, assuming that the antenna gain in both far-field and near-field is known:

1. Passive antenna radiation pattern is measured in the near-field in amplitude and phase.
2. NF antenna radiation pattern is transformed to far-field.
3. Gain pattern is calculated for NF and FF.
4. Radiated Power $RadiatedPower_{NF}$ (equivalent of EIRP in the NF) is measured in the NF at selected θ - and ϕ -angle combinations.
5. EIRP is then calculated for each measurement point.

It has to be noted that test conditions and detailed procedures for steps 1 through 3

are described in Section 5.

With the $RadiatedPower_{NF}$ measured on a single point in the near-field and the gain G_{NF} and G_{FF} in the near-field and the far-field, respectively, the EIRP at the same point in the far-field can be calculated as follows

$$EIRP(\theta_i, \phi_j)[mW] = RadiatedPower_{NF}(\theta_i, \phi_j)[mW] \frac{G_{FF}(\theta_i, \phi_j)}{G_{NF}(\theta_i, \phi_j)} \quad \text{Equation 22}$$

6.2.3.1 GSM

The radiated power shall be measured according to [6], Section 5.3.4, with the following exceptions in the procedure:

- ▶ References on the use of phantoms or any other positioning guidelines in the test chamber shall be ignored.
- ▶ The VUT shall be positioned in the test chamber as described in Section 4.2.
- ▶ References to sample steps or measurements at other angle combinations shall be ignored. The radiated power shall be measured only at selected θ - and ϕ -angle combinations.
- ▶ No total radiated power (TRP) shall be calculated.
- ▶ Guidelines for the reverberation chamber method shall be ignored.

6.2.3.2 UMTS

The radiated power shall be measured according to [7], Section 6.1.1.4, with the following exceptions in the procedure:

- ▶ References on the use of phantoms or any other positioning guidelines in the test chamber shall be ignored.
- ▶ The VUT shall be positioned in the test chamber as described in Section 4.2.
- ▶ References to sample steps or measurements at other angle combinations shall be ignored. The radiated power shall be measured only at selected θ - and ϕ -angle combinations.
- ▶ No TRP shall be calculated.
- ▶ Guidelines for the reverberation chamber method shall be ignored.

6.2.3.3 LTE

The radiated power shall be measured according to [7], Section 6.1.5.4 for E-UTRA FDD bands or Section 6.1.6.4 for E-UTRA TDD bands, with the following exceptions in the initial conditions and procedure:

- ▶ References on the use of phantoms or any other positioning guidelines in the test chamber shall be ignored.
- ▶ The VUT shall be positioned in the test chamber as described in Section 4.2.
- ▶ References to sample steps or measurements at other angle combinations shall be ignored. The radiated power shall be measured only at selected θ - and ϕ -angle combinations.

- ▶ No TRP shall be calculated.
- ▶ Guidelines for the reverberation chamber method shall be ignored.

6.2.3.4 5G NR

For standalone (SA) and EN-DC (non-standalone, NSA) operation, the radiated power shall be measured according to [12], Section 6.2.1.1, with the following exceptions in the initial conditions and procedure:

- ▶ References on the use of phantoms or any other positioning guidelines in the test chamber shall be ignored.
- ▶ The VUT shall be positioned in the test chamber as described in Section 4.2.
- ▶ References to sample steps or measurements at other angle combinations shall be ignored. The radiated power shall be measured only at selected θ - and ϕ -angle combinations.
- ▶ No TRP shall be calculated.

6.2.3.5 Direct communication

a) LTE V2X sidelink

The radiated power shall be measured according to [3], Section 6.2.2G, with the following exceptions in the procedure:

- ▶ The VUT shall be positioned in the test chamber as described in Section 4.2.
- ▶ Radiated power shall be measured instead of conducted power.
- ▶ Only the 10 MHz BW configuration shall be tested.
- ▶ The radiated power shall be measured only at selected θ - and ϕ -angle combinations.
- ▶ UE power class test requirements shall be ignored.

b) 802.11p

The radiated power shall be measured according to [4], Section 5.3.3, with the following exceptions:

- ▶ The VUT shall be positioned in the test chamber as described in Section 4.2.
- ▶ Radiated power shall be measured instead of conducted power.
- ▶ Guidelines to measure power spectral density and transmit power control shall be ignored.
- ▶ The radiated power shall be measured only at selected θ - and ϕ -angle combinations.
- ▶ Any reference to compliance limits shall be ignored.

6.2.3.6 Vehicles implementing transmit antenna diversity

For vehicles implementing transmit antenna diversity, or transmit antenna switching, each transmitter chain needs to be measured separately for both OTA-conventional and OTA-combinational methods. The OBU manufacturer needs to provide the means to control which transmitter chain is active and disable any dynamic switching.

Results shall be reported per antenna and/or switching state.

6.2.4 OTA receiver performance

This Section describes how to derive the radiated sensitivity of the individual communication technologies at any θ - and ϕ -angle combination, regardless of the method used (see Sections 6.2.1 and 6.2.2). The measured results derived in Section 6.3 are based on the EIS, a measure of the received sensitivity in the far-field. Additional calculations may be needed to provide final EIS values. The appropriate calculations depend on the individual test-range type and measurement method used to determine the received sensitivity. Such specific calculations are not part of this document.

In many cases a direct far-field measurement of the EIS is not possible due to the large range length required for testing in far-field conditions, as described in Section 4.1. In such cases, EIS can be calculated from measurements in the near-field assuming that the antenna gain in both far-field and near-field is known:

1. Passive antenna radiation pattern is measured in the near-field in amplitude and phase.
2. NF antenna radiation pattern is transformed to far-field.
3. Gain pattern is calculated for NF and FF.
4. Radiated Sensitivity $RadiatedSensitivity_{NF}$ (equivalent of EIS in the NF) is measured in the NF at selected θ - and ϕ -angle combinations.
5. EIS is then calculated for each measurement point.

It has to be noted that test conditions and detailed procedure for steps 1 through 3 are described in Section 5.

With the $RadiatedSensitivity_{NF}$ measured on a single point in the near field and the gain G_{NF} and G_{FF} in the near field and the far field respectively, the EIS at the same point in the far field can be calculated as follows

$$EIS(\theta_i, \phi_j)[mW] = RadiatedSensitivity_{NF}(\theta_i, \phi_j)[mW] \frac{G_{NF}(\theta_i, \phi_j)}{G_{FF}(\theta_i, \phi_j)} \quad \text{Equation 23}$$

6.2.4.1 GSM

The radiated sensitivity shall be measured by adjusting the downlink signal level to a RBERII value of $2.00\% \pm 0.2\%$ according to [6], Section 6.3.4, with the following exceptions in the procedure:

- ▶ References on the use of phantoms or any other positioning guidelines in the test chamber shall be ignored.

- ▶ The VUT shall be positioned in the test chamber as described in Section 4.2.
- ▶ References to sample steps or measurements at other angle combinations shall be ignored. The radiated sensitivity shall be measured only at selected θ - and ϕ -angle combinations.
- ▶ No TRS shall be calculated.
- ▶ Guidelines for the reverberation chamber method shall be ignored.

6.2.4.2 UMTS

The radiated sensitivity shall be measured by adjusting the downlink signal level to a BER value of $1\% \pm 0.2\%$ using 20000 or more bits according to [7], Section 7.1.1.4, with the following exceptions in the procedure:

- ▶ References on the use of phantoms or any other positioning guidelines in the test chamber shall be ignored.
- ▶ The VUT shall be positioned in the test chamber as described in Section 4.2.
- ▶ References to sample steps or measurements at other angle combinations shall be ignored. The radiated sensitivity shall be measured only at selected θ - and ϕ -angle combinations.
- ▶ No TRS shall be calculated.
- ▶ Guidelines for the reverberation chamber method shall be ignored.

6.2.4.3 LTE

The radiated sensitivity shall be measured by adjusting the downlink signal level to 95 % throughput of the maximum throughput of the reference channel according to [7], Section 7.1.5.4 for E-UTRA FDD bands or Section 7.1.6.4 for E-UTRA TDD bands, with the following exceptions in the initial conditions and procedure:

- ▶ References on the use of phantoms or any other positioning guidelines in the test chamber shall be ignored.
- ▶ The vehicle shall be positioned in the test chamber as described in Section 4.2.
- ▶ References to sample steps or measurements at other angle combinations shall be ignored. The radiated sensitivity shall be measured only at selected θ - and ϕ -angle combinations.
- ▶ No TRS shall be calculated.
- ▶ Guidelines for the reverberation chamber method shall be ignored.

6.2.4.4 5G NR

For Standalone (SA) and EN-DC (non-standalone, NSA) operation, the radiated sensitivity shall be measured by adjusting the downlink signal level to 95 % throughput of the maximum throughput of the reference channel according to [12], Section 6.2.1.2, with the following exceptions in the initial conditions and procedure:

- ▶ References on the use of phantoms or any other positioning guidelines in

the test chamber shall be ignored.

- ▶ The vehicle shall be positioned in the test chamber as described in Section 4.2.
- ▶ References to sample steps or measurements at other angle combinations shall be ignored. The radiated power shall be measured only at selected θ - and ϕ -angle combinations.
- ▶ No TRS shall be calculated.

6.2.4.5 Direct communication

a) LTE V2X sidelink

The radiated sensitivity shall be measured by adjusting the downlink signal level to 95 % throughput of the maximum throughput of the reference channel according to [3], Section 7.3G, with the following exceptions in the procedure:

- ▶ The vehicle shall be positioned in the test chamber as described in Section 4.2.
- ▶ Radiated sensitivity shall be measured instead of conducted sensitivity.
- ▶ Only the 10 MHz BW configuration shall be tested.
- ▶ The radiated sensitivity shall be measured only at selected θ - and ϕ -angle combinations.
- ▶ Reference sensitivity values shall be ignored.

b) 802.11p

The radiated sensitivity shall be measured according to according to [4], Section 5.3.8, with the following exceptions:

- ▶ The VUT shall be positioned in the test chamber as described in Section 4.2.
- ▶ Radiated sensitivity shall be measured instead of conducted sensitivity.
- ▶ The downlink signal level is adjusted to a PER value of 10%.
- ▶ The radiated sensitivity shall be measured only at selected θ - and ϕ -angle combinations.
- ▶ Any reference to compliance limits shall be ignored.

6.2.4.6 GNSS

The National Marine Electronics Association (NMEA 0183) Standard [11] defines the format by which data is transferred by all GNSS receivers. The data, or message, is in sentence format and includes information such as SNR (C/N0), Satellite ID and Number of Satellites in View. The NMEA data can be transferred using different types of communications interfaces such as e.g. RS-232, USB, Bluetooth, Wi-Fi. Through

these interfaces the NMEA data is collected, and the pertinent information parsed and evaluated. From this information, the tracking sensitivity of the GPS receiver can be estimated.

A GNSS simulator is used for this measurement and is configured to emulate the GNSS scenario under test. Table 5 outlines the applicable GNSS scenarios as defined in 3GPP TS 37.571-5 [10].

Table 5: GNSS scenarios

GNSS service	Band	GNSS scenario		
GPS C/A	L1	3GPP TS 37.571-5 Section 6.2.1.2.1 for 3GPP TS 37.571-1 subclause 7 Sub-test case number 1	Pattern	[10] Table 6.2.1.2.2-7
			Sensitivity offset	
GPS	L1C, L2C, L5	3GPP TS 37.571-5 Section 6.2.1.2.1 for 3GPP TS 37.571-1 subclause 7 Sub-test case number 4	Pattern	[10] Table 6.2.1.2.1-6
			Sensitivity offset	
Galileo	E1, E5a, E5b	3GPP TS 37.571-5 Section 6.2.1.2.1 for 3GPP TS 37.571-1 subclause 7 Sub-test case number 8	Pattern	[10] Table 6.2.1.2.1-6
			Sensitivity offset	
GLONASS	G1, G2	3GPP TS 37.571-5 Section 6.2.1.2.1 for 3GPP TS 37.571-1 subclause 7 Sub-test case number 5	Pattern	[10] Table 6.2.1.2.1-6
			Sensitivity offset	
BDS	B1I, B1C	3GPP TS 37.571-5 Section 6.2.1.2.1 for 3GPP TS 37.571-1 subclause 7 Sub-test case number 9	Pattern	[10] Table 6.2.1.2.1-6
			Sensitivity offset	

The measurement comprises two steps. The pattern is obtained by measuring the ratio of carrier to noise (C/N0) over the measuring angle range defined in Sections 6.2.1 and 6.2.2, with both vertical and horizontal polarisations. An offset is then performed at the peak C/N0 in the pattern using the criteria defined below and then applied to the C/N0 pattern to obtain the sensitivity result.

Pattern measurement:

- 1) Configure the GNSS satellite simulator to run the test scenario defined in Table 5. Set the signal level (sum of the satellites) to be in the linear operating region of the GNSS receiver. A power level commonly used for this measurement is -130 dBm. A fixed signal level will be used to obtain the pattern.
- 2) Send a command to the EUT to begin transmitting GNSS data.
- 3) Move to first point/polarisation. Wait 5 seconds to allow the GNSS receiver to adapt (and report) to the current C/N0 level. Average the visible satellites of the selected scenario. The measurement is considered stable and accurate once five C/N0 measurement reports have been received and the average C/N0 among the five reports has a maximum deviation of less than 1 dB. C/N0 results may be considered outliers and removed from the average when the results deviate (higher or lower) by more than 1.5 dB from the median C/N0 of the reported satellites. Both vertical and horizontal polarisations shall

be measured.

- 4) Continue to the next point in space/polarisation and repeat step 3 until all points as defined in Sections 6.2.1 or 6.2.2 has been measured.

Sensitivity offset:

Pattern re-use is possible if measuring multiple GPS scenarios in the same band, i.e. the carrier frequency is within $\pm 100\text{MHz}$ from the carrier used for pattern measurement. For example, if the GPS pattern in band L1 is measured, these results can be used for a Galileo band E1 sensitivity offset.

- 1) Determine the peak C/N0 in the upper hemisphere of the pattern. Identify the location in angle (Phi, Theta) and the associated polarisation.
- 2) Move to the position/polarisation at which the peak C/N0 occurred without disturbing the setup to minimise the uncertainty.
- 3) Set the power level of the GNSS simulator to that with which the pattern was measured.
- 4) Step down the power and at each new power level wait 10 seconds to allow the GNSS receiver to adapt (and report) to the current power level before monitoring C/N0 values.
- 5) Average the satellites in the measurement report. C/N0 results may be considered outliers and removed from the average when the results deviate (higher or lower) by more than 1.5 dB from the median C/N0 of the reported satellites. The sensitivity passes if ten measurement reports with four or more satellites are received and the deviation in the average C/N0 is less than 1 dB. A maximum of 20 consecutive reports can be monitored and if the pass criteria is not achieved within those 20 reports, then the sensitivity fails. The maximum GNSS sensitivity search step size shall be no more than 0.5 dB when the satellite power level is near the GNSS sensitivity level.
- 6) Normalise the C/N0 pattern data using the results of the sensitivity offset to obtain the sensitivity results.

If the receiver loses lock (no longer reports GPS data) during the sensitivity search, the signal level can be increased (e.g. -130 dBm) and dwell time increased at which the GNSS receiver can regain lock and then the sensitivity search can continue. When adjusting the power level in large steps, the response time for accurate C/N0 for the GNSS receiver increases. Performing the offset measurement more than once increases the accuracy of the results.

6.2.4.7 Vehicles implementing receive antenna diversity

The usage of receiver diversity (at least two ports) is the baseline implementation for cellular communications (e.g. LTE and NR, but also very common for WCDMA). In this case, the procedure to perform sensitivity measurements differs between OTA methods:

- ▶ In case of OTA-conventional method, OTA receiver performance measurements shall be performed with all receivers active.
- ▶ In case of OTA-combinational method, two sets of measurements are

required at the selected θ - and ϕ -angle combinations:

- OTA receiver performance measurements shall be performed separately per receiver while the other receivers are disabled.
- OTA receiver performance measurements shall be performed with all receivers active.

The OBU manufacturer needs to provide the means to control which receiver chain is active and to disable any diversity or switching.

6.3 Result analysis

In this Section, spatially averaged quantities are introduced and are applicable to both OTA methods. Moreover, Section 6.3.3 describes how the results of the antenna pattern and OTA system measurements are combined when using the OTA-combinational method.

6.3.1 Spatially averaged quantities

As already indicated in Section 5.3.1, the various communication technologies of vehicles, such as mobile communication, direct communication (V2V, V2I, V2P) and satellite communication, have different service characteristics. Each service has specific requirements for the radiation direction of the vehicular antenna.

Spatially averaged quantities can be good key performance indicators to assess the system performance of a certain communication technology. The dark-grey marked areas in the below figures indicate different spatial areas of interest. It needs to be noted that the definition of elevation angle range refers to the z-axis, counting from the zenith to the nadir.

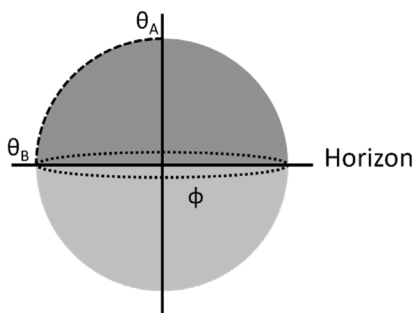

Figure 20: Definition of upper hemisphere

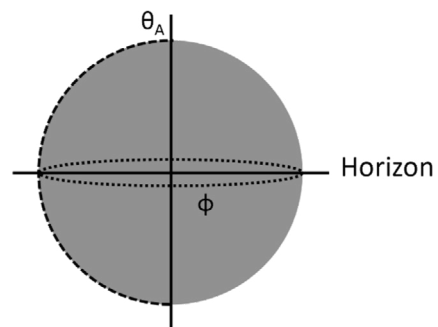

Figure 21: Definition of complete sphere

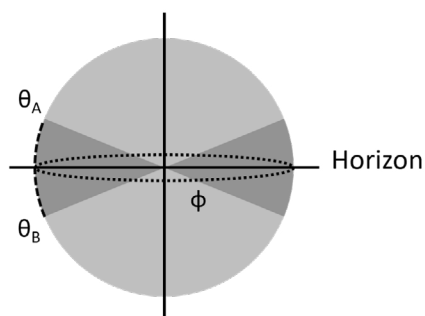

Figure 22: Definition of near horizon

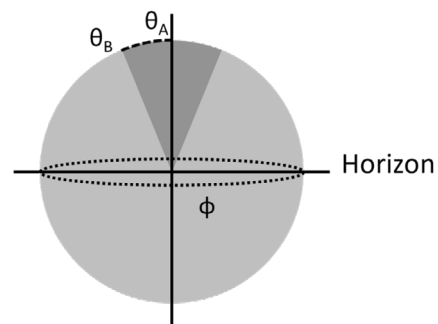

Figure 23: Definition of near zenith

Figure 20 indicates the upper hemisphere of interest. To some extent this definition may be used to assess the system performance of satellite communication systems in vehicular applications. Key metrics therefore are upper hemisphere radiated power (UPHRP) and upper hemisphere isotropic sensitivity (UPHIS).

Figure 21 indicates the complete sphere of interest. The complete sphere plays a significant role in the assessment of the system performance of consumer devices, such as handsets, tablets, laptop, etc., with the key metrics including total radiated power (TRP) and total isotropic sensitivity (TIS). Due to the nature of vehicles driving on the ground this metric is not well suited for the assessment of vehicular antennas.

Figure 22 indicates the area on the sphere around the horizon. This area is of most interest for mobile network, vehicle-to-vehicle and vehicle-to-infrastructure communication. Here, the performance indicators are called near horizon partial radiated power (NHPRP) and near horizon partial isotropic sensitivity (NHPIS).

Figure 23 indicates the area on the sphere around the zenith. The key metrics, near zenith partial radiated power (NZPRP) or near zenith partial isotropic sensitivity (NZPIS), are good performance indicators of satellite communication systems.

6.3.2 Analysis angle range definition

The analysis range for OTA measurements is expected to be identical to the analysis range of the antenna pattern measurements. Therefore, the information provided in Section 5.3.2 also applies to OTA system measurements.

6.3.3 Combination of results for OTA-combinational method

To speed up the acquisition process of the OTA system measurements, a combination of the results of the OTA measurements at selected angle combinations (Section 6.2.2) and of the results of the radiation pattern measurement (Section 5) is outlined in the following sections.

For vehicles implementing antenna diversity following the description in Sections 5.2.5, 6.2.3.6 and 6.2.4.7, the combination of results shall be done per antenna and/or switching state.

6.3.3.1 Radiated power

The combination of results is based on:

$$\text{EIRP}(\theta, \phi) = P_{\text{AUT,out}} + G_{\text{AUT}}(\theta, \phi), \text{ in dBm} \quad \text{Equation 24}$$

To compensate for statistical errors, an average power at the vehicular antenna's input port ($P_{\text{AUT,TX}}$) is calculated by n EIRP results (e.g. as of Equation 22), obtained from n OTA measurements at selected angle combinations (θ_k, ϕ_k) and the corresponding antenna gain. This average power is calculated separately for each polarisation

$$P_{\theta \text{ AUT,TX}} = 10 \cdot \log \left(\frac{1}{n} \cdot \sum_{k=1}^n 10^{(\text{EIRP}_{\theta}(\theta_k, \phi_k) - G_{\text{AUT}\theta}(\theta_k, \phi_k))/10} \right), \text{ in dBm} \quad \text{Equation 25}$$

$$P_{\phi \text{ AUT,TX}} = 10 \cdot \log \left(\frac{1}{n} \cdot \sum_{k=1}^n 10^{(\text{EIRP}_{\phi}(\theta_k, \phi_k) - G_{\text{AUT}\phi}(\theta_k, \phi_k))/10} \right), \text{ in dBm} \quad \text{Equation 26}$$

Where

n:	number of reference OTA measurements
$EIRP_{\theta}(\theta_k, \phi_k), EIRP_{\phi}(\theta_k, \phi_k)$:	equivalent isotropic radiated power in dBm, θ and ϕ polarisation derived in Section 6.2.3
$G_{AUT_{\theta}}(\theta, \phi), G_{AUT_{\phi}}(\theta, \phi)$:	gain value in dB of AUT, θ and ϕ polarisation, derived in Section 5

The EIRP at θ - and ϕ - angle combinations other than those measured at the OTA measurement campaign can be calculated by

$$EIRP_{\theta \text{ calc}}(\theta_i, \phi_j) = P_{\theta \text{ AUT, TX}} + G_{AUT_{\theta}}(\theta_i, \phi_j), \text{ in dBm} \quad \text{Equation 27}$$

$$EIRP_{\phi \text{ calc}}(\theta_i, \phi_j) = P_{\phi \text{ AUT, TX}} + G_{AUT_{\phi}}(\theta_i, \phi_j), \text{ in dBm} \quad \text{Equation 28}$$

The combined EIRP can be derived by

$$EIRP_{\text{calc}}(\theta_i, \phi_j) = EIRP_{\theta \text{ calc}}(\theta_i, \phi_j) + EIRP_{\phi \text{ calc}}(\theta_i, \phi_j)$$

6.3.3.2 Isotropic sensitivity

The combination of results is based on:

$$EIS(\theta, \phi) = P_{AUT, in} - G_{AUT}(\theta, \phi), \text{ in dB} \quad \text{Equation 29}$$

To compensate for statistical errors, an average power at the vehicular antenna's input port ($P_{AUT, RX}$) is calculated by n EIS results (e.g. as of equation 23), obtained from n OTA measurements at selected angle combinations (θ_k, ϕ_k) and the corresponding antenna gain. This average power is calculated separately for each polarisation

$$P_{\theta \text{ AUT, RX}} = 10 \cdot \log\left(\frac{1}{n} \cdot \sum_{k=1}^n 10^{(EIS_{\theta}(\theta_k, \phi_k) + G_{AUT_{\theta}}(\theta_k, \phi_k))/10}\right), \text{ in dBm} \quad \text{Equation 30}$$

$$P_{\phi \text{ AUT, RX}} = 10 \cdot \log\left(\frac{1}{n} \cdot \sum_{k=1}^n 10^{(EIS_{\phi}(\theta_k, \phi_k) + G_{AUT_{\phi}}(\theta_k, \phi_k))/10}\right), \text{ in dBm} \quad \text{Equation 31}$$

Where

n:	number of reference OTA measurements
$EIS_{\theta}(\theta_k, \phi_k), EIS_{\phi}(\theta_k, \phi_k)$:	equivalent isotropic sensitivity in dBm, θ and ϕ polarisation derived in 6.2.4
$G_{AUT_{\theta}}(\theta, \phi), G_{AUT_{\phi}}(\theta, \phi)$:	gain value in dB of AUT, θ and ϕ polarisation, derived in Section 5

The EIS at θ - and ϕ - angle combinations other than those measured at the OTA measurement campaign can be calculated by

$$EIS_{\theta \text{ calc}}(\theta_i, \phi_j) = P_{\theta \text{ AUT, RX}} - G_{AUT_{\theta}}(\theta_i, \phi_j), \text{ in dBm} \quad \text{Equation 32}$$

$$EIS_{\phi \text{ calc}}(\theta_i, \phi_j) = P_{\phi \text{ AUT,RX}} - G_{\text{AUT } \phi}(\theta_i, \phi_j), \text{ in dBm} \quad \text{Equation 33}$$

The combined EIS can be derived by

$$EIS_{\text{calc}}(\theta_i, \phi_j) = EIS_{\theta \text{ calc}}(\theta_i, \phi_j) + EIS_{\phi \text{ calc}}(\theta_i, \phi_j)$$

6.3.4 Calculation of spatially averaged quantities

This section describes how to compute the spatially averaged quantities (introduced in Section 6.3.1) based on the radiated power and isotropic sensitivity as derived in Section 6.2.3 and 6.2.4. The same basic principles for the average gain as outlined in Section 5.3.4 also apply to the spatially averaged EIRP and EIS quantities. It needs to be noted that all angular values used in the subsequent calculations have to be converted into radian following this conversion scheme:

$$\theta[\text{rad}] = \theta [^\circ] \cdot \frac{\pi}{180^\circ} \quad \text{Equation 34}$$

$$\phi[\text{rad}] = \phi [^\circ] \cdot \frac{\pi}{180^\circ} \quad \text{Equation 35}$$

Based on the individual service dependant analysis angle range as defined in Section 5.3.2 the elevation range is divided into p Theta-intervals

$$p = \frac{\theta_B - \theta_A}{\Delta\theta} + 1 \quad \text{Equation 36}$$

Similarly the azimuth range is divided into q Phi-intervals

$$q = \frac{\phi_B - \phi_A}{\Delta\phi} + 1 \quad \text{Equation 37}$$

$\Delta\theta$ and $\Delta\phi$ need to meet these conditions

$$\Delta\theta \leq \frac{c_0}{f \cdot D} \quad \text{Equation 38}$$

$$\Delta\phi \leq \frac{c_0}{f \cdot D} \quad \text{Equation 39}$$

The basic principle of spatially averaged quantities is to integrate EIRP or EIS quantities over a certain horizontal elevation range.

If the EIRP and EIS quantities are reported in units of dBm, the data needs to be converted to linear units of milliwatts (mW) to perform the calculations in the later subsections.

6.3.4.1 Partial radiated power

The partial radiated power is calculated as follows:

$$PRP = \frac{\Delta\theta \cdot \Delta\phi}{4\pi} \cdot \left(\frac{cut_0 + cut_p}{2} + \sum_{i=1}^{p-1} cut_i \right) \quad \text{Equation 40}$$

Where

$$cut_i = \sum_{j=0}^{q-1} [EIRP_{\theta}(\theta_i, \phi_j) + EIRP_{\phi}(\theta_i, \phi_j)] \cdot \sin \theta_i \quad \text{Equation 41}$$

represents the weighted sum of each conical cut.

In case the EIRP was derived by the combination of OTA measurement results and antenna gain as defined in Section 6.3.3 these definitions apply

$$EIRP_{\theta}(\theta_i, \phi_j) = EIRP_{\theta \text{ calc}}(\theta_i, \phi_j)$$

$$EIRP_{\phi}(\theta_i, \phi_j) = EIRP_{\phi \text{ calc}}(\theta_i, \phi_j)$$

For vehicles implementing transmit antenna diversity, or transmit antenna switching, PRP shall be calculated and reported per antenna and/or switching state.

6.3.4.2 Partial isotropic sensitivity

The partial isotropic sensitivity is calculated as follows:

$$PIS = \frac{4 \cdot \pi}{\Delta\theta \cdot \Delta\phi \cdot \left(\frac{cut_0 + cut_p}{2} + \sum_{i=1}^{p-1} cut_i \right)} \quad \text{Equation 42}$$

where

$$cut_i = \sum_{j=0}^{q-1} \left[\frac{1}{EIS_{\theta}(\theta_i, \phi_j)} + \frac{1}{EIS_{\phi}(\theta_i, \phi_j)} \right] \cdot \sin \theta_i \quad \text{Equation 43}$$

represents the weighted sum of each conical cut.

If the EIS was derived by the combination of OTA measurement results and antenna gain, as defined in Section 6.3.3, these definitions apply:

$$EIS_{\theta}(\theta_i, \phi_j) = EIS_{\theta \text{ calc}}(\theta_i, \phi_j)$$

$$EIS_{\phi}(\theta_i, \phi_j) = EIS_{\phi \text{ calc}}(\theta_i, \phi_j)$$

For vehicles implementing receive antenna diversity, PIS shall be reported for the combination of all receivers and therefore the calculation of spatially averaged quantities differs between OTA methods:

- ▶ For the OTA-conventional method, and since OTA receiver performance measurements are performed with all receivers active, PIS is calculated using Equations 42 and 43.
- ▶ For the OTA-combinational method, both gain pattern measurements and OTA receiver performance measurements are performed separately per receiver/antenna. In this case, PIS is calculated separately per receiver/antenna (PIS_i for n-number of receivers) and then combined into one single result PIS_{combined} as described in Equation 44.

$$\frac{1}{PIS_{combined}} = \frac{1}{PIS_0} + \frac{1}{PIS_1} + \dots + \frac{1}{PIS_n} \quad \text{Equation 44}$$

This is only valid under the assumption that combined EIS of the individual receivers (as described in Equation 24) is equal to the EIS when measured with all receivers active at each selected θ - and ϕ -angle combination. Otherwise, the OTA-conventional method shall be used.

$$\frac{1}{EIS_{combined}(\theta_i, \phi_j)} = \frac{1}{EIS_0(\theta_i, \phi_j)} + \frac{1}{EIS_0(\theta_i, \phi_j)} + \dots + \frac{1}{EIS_n(\theta_i, \phi_j)} \quad \text{Equation 45}$$

This method is only applicable when the EIS in far-field can be analysed. Its applicability to sensitivity measurements based on near-field to far-field transformation is for further study.

6.3.5 Peak EIRP

The peak EIRP can be calculated based on the OTA-conventional method or on the OTA-combinational method.

It can be evaluated for each of the analysis angle ranges, as defined in Section 5.3.2, but it should be ensured that the AUT's main beam is within the analysed angular range.

Some regulations specify a maximum EIRP without defining a particular angular range. In such cases, it is advised to perform the peak EIRP evaluation using the service-independent peak analysis ranges, as defined in Section 5.3.2.

The "service-independent absorbing peak analysis" range in Table 2 defines a θ_b analysis range of 180°. It should be noted that the same principles of the angular extrapolation process outlined in Section 5.3.5 apply to the peak EIRP analysis. In the OTA-conventional case, the average radiated power would need to be continuously calculated as the criterion to stop the angular extrapolation process.

Peak EIRP calculation of OTA-conventional method:

The peak EIRP is evaluated based on conventional OTA measurements as described in Section 6.2.3.

$$PeakEIRP = Max(EIRP(\theta, \phi)) \quad \text{Equation 46}$$

With

$$EIRP(\theta, \phi) = EIRP_{\theta}(\theta, \phi) + EIRP_{\phi}(\theta, \phi)$$

Peak EIRP calculation of OTA-combinational method:

The peak EIRP is evaluated based on the peak gain derived Section 5.3.5 and the average power at the vehicular antenna's input port ($P_{AUT, TX}$), as defined in Section 6.3.3.1.

$$PeakEIRP = P_{AUT, TX} + PeakGain \quad \text{Equation 47}$$

Annex A: Criteria to determine a reduced D

This section complements Section 4.1. by providing certain restrictions and requirements that would need to be fulfilled in order to use that smaller D.

A.1 Definitions

In this proposal the following is used:

D	antenna aperture size as in Section 4.1
D_{reduced}	A smaller D that is possible to be used throughout the TR in cases where the criteria below are met.
$D_{\text{reduced},+20}$	$D_{\text{reduced}} \cdot 1.2$ or larger, used for evaluating convergence
$D_{\text{reduced},+50}$	$D_{\text{reduced}} \cdot 1.5$ or larger, and at least 20% larger than $D_{\text{reduced},+20}$, used for evaluating convergence
PAG	Partial average gain for the service of interest
PAG_{reduced}	PAG calculated for the service of interest using D_{reduced}
$PAG_{\text{reduced},+20}$	PAG calculated for the service of interest using $D_{\text{reduced},+20}$
$PAG_{\text{reduced},+50}$	PAG calculated for the service of interest using $D_{\text{reduced},+50}$

A.2 Criteria for using a smaller D

Under certain circumstances the final tests and results can be based on the use of a D smaller than the largest dimension of the vehicle, D_{reduced} . This can only be done when the following criteria are met.

- 1) The antenna location is known
- 2) In case the antenna can be centered in the measurement system both requirements a) and b) below must be fulfilled:
 - a) D_{reduced} is not less than 10 times the wavelength
 - b) D_{reduced} is not less than the size of the antenna unit or module (the antenna module in this case is the actual module containing the antenna elements, it does not include other vehicle parts, separate ground planes or other parts separately mounted on the vehicle)
- 3) In the event the antenna cannot be centred in the measurement system both requirements a) and b) below must be fulfilled:
 - a) D_{reduced} is not less than 10 times the wavelength + two times the distance from the centre of the antenna to the centre of the measurement system
 - b) D_{reduced} is not less than the size of the antenna unit or module + two times the distance from the centre of the antenna to the centre of the measurement system

- 4) The antenna system is localised (not distributed)
- 5) One of the two convergence criteria as in A.2.1 and A.2.2 below is fulfilled

It should be noted that $D_{reduced}$ is related to the antenna aperture and a function of the antenna system and not the measurement system. Hence, $D_{reduced}$ for an antenna system can be used on other test ranges than the one on which the convergence verification was performed.

The antenna being evaluated for the convergence should be essentially the same as the antenna to be tested, e.g. the antenna might have retuning or radiator re-design done. However, no overall structural change, additions of parasitic elements or similar may be done without re-verifying the $D_{reduced}$. Furthermore, the area of the vehicle around the antenna should remain essentially the same, e.g. substantial changes of part shapes, cut outs, materials, mounting fixtures or other nearby parts significantly effecting the radiating area require a re-verification of the $D_{reduced}$.

A.2.1 Convergence criterion (option 1)

The convergence here needs to be evaluated for each frequency band and for the service of interest using angular ranges specified in Section 5.3.2.

For the below calculations the partial average gain (PAG) should be calculated using the analysis range of interest from Section 5.3.2 and using averaging as in 6.3.5.1 where EIRP should be substituted by linear gain. For all measurements and evaluations, the same gain calibrations should be used.

For the highest frequency in each band to be tested, using the correct VUT and antenna combination, the following passive measurements should be performed (note that in near-field systems this will mainly affect the sample spacing):

- i) Assuming a D covering the whole vehicle, measure the VUT so that the applicable Theta and Phi analysis range from Section 5.3.2 can be evaluated, and then calculate the $PAG = PAG_D$.
- ii) Reduce D to D_1 (not larger than $0.9D$, not smaller than $0.7D$) and measure the VUT so that the applicable Theta and Phi analysis range from Section 5.3.2 can be evaluated, then calculate $PAG = PAG_1$.
- iii) Repeat ii) for D_i with $0.9D_{i-1} \leq D_i \leq 0.7D_{i-1}$ until $0.9D_N \leq D_{reduced} \leq 0.7D_N$ and at least one in between measurement has been done.
- iv) Assuming $D_{reduced}$, measure the VUT so that the applicable Theta and Phi analysis range from Section 5.3.2 can be evaluated, then calculate the $PAG = PAG_{reduced}$.

The criterion is considered satisfied when the absolute differences between $PAG_{reduced}$ and the other PAGs are less than $[0.5]dB$, i.e. that

$$|PAG_{reduced} - PAG_D| \leq [0.5]dB$$

$$|PAG_{reduced} - PAG_1| \leq [0.5]dB$$

...

$$|PAG_{reduced} - PAG_N| \leq [0.5]dB$$

are satisfied.

A.2.1 Convergence criterion (option 2)

The convergence here needs to be evaluated for each frequency band and for the service of interest using angular ranges specified in Section 5.3.2.

For the below calculations the PAG should be calculated using the analysis range of interest from Section 5.3.2 and using averaging as in 6.3.5.1 where EIRP should be substituted by linear gain. For all measurements and evaluations the same gain calibrations should be used.

For the highest frequency in each band to be tested, using the correct VUT and antenna combination, the following passive measurements should be performed (note that in near field systems this will mainly effect the sample spacing):

- i) Assuming a D covering the whole vehicle, measure the VUT so that the applicable Theta and Phi analysis range from Section 5.3.2 can be evaluated.
- ii) Assuming $D_{\text{reduced,+50}}$ measure the VUT so that the applicable Theta and Phi analysis range from Section 5.3.2 can be evaluated. This test can be omitted if $D_{\text{reduced,+50}}$ is covering the whole vehicle.
- iii) Assuming $D_{\text{reduced,+20}}$ measure the VUT so that the applicable Theta and Phi analysis range from Section 5.3.2 can be evaluated.
- iv) Assuming D_{reduced} measure the VUT so that the applicable Theta and Phi analysis range from Section 5.3.2 can be evaluated.

Using the data from i), ii), iii) and iv) above, calculate the PAG_D , $PAG_{\text{reduced+50}}$, $PAG_{\text{reduced+20}}$ and PAG_{reduced} .

The criterion is considered satisfied in case the absolute differences between PAG_{reduced} and the three (or two) other PAGs are less than [0.5]dB, i.e. that

$$|PAG_{\text{reduced}} - PAG_D| \leq [0.5]dB$$

and

$$|PAG_{\text{reduced}} - PAG_{\text{reduced,+50}}| \leq [0.5]dB$$

and

$$|PAG_{\text{reduced}} - PAG_{\text{reduced,+20}}| \leq [0.5]dB$$

are satisfied.

Annex B (informative): Survey and analysis of existing work in the relevant SDOs

In this section, we list the work of major standards developing organisations (SDOs), however we make no claim for completeness. Beside the definition of test limits, all published material gives a very detailed and exact definition of the test and measurement environment. Meaningful requirements with minimised measurement uncertainty and a high level of reproducibility are basic requirements for making a test definition for validation and certification purposes.

B.1 3GPP

In 3GPP, extensive work has been done to produce specifications for methods, procedures and requirements for OTA tests. The following lists the specification and purpose:

- ▶ TS 34.114 – ‘User Equipment (UE)/Mobile Station (MS) Over The Air (OTA) antenna performance; Conformance testing’. Describes the test procedure for radiated performances measurements of the 3G/2G user equipment/mobile stations (UE/MS) in active mode in both the uplink and the downlink, TRP and TRS.
- ▶ TS 37.144 – ‘User Equipment (UE) and Mobile Station (MS) GSM, UTRA and E-UTRA over the air performance requirements’. Document to establish over-the-air antenna minimum requirements for user equipment (UE) and mobile station (MS).
- ▶ TS 37.544 – ‘User Equipment (UE) Over The Air (OTA) performance; Conformance testing’. Describes the test procedure for radiated performance measurements of the user equipment (UE) UMTS/LTE for TRP/TRS with the extension of multiple receiving antennas and also include the definition of recommended performance values.
- ▶ TS 38.561 – ‘UE TRP (Total Radiated Power) and TRS (Total Radiated Sensitivity) requirements and test methodologies for FR1 (NR SA and EN-DC)’. Describes the test procedure for radiated performance measurements of the user equipment (UE) NR FR1, both SA and EN-DC, for TRP/TRS. It includes the definition of minimum requirements.

Current work in 3GPP also includes the enhancement of OTA measurements for NR (New Radio) for cm- and mm-wave frequencies as well as OTA MIMO testing. The 3GPP standards define the details of the measurement procedure and test environment.

B.2 CTIA

CTIA has developed a comprehensive test plan for OTA performance requirements (Test Plan for Wireless Device Over-the-Air Performance, currently available as version 6.0.x, September 2023) that covers GSM, UMTS, LTE and NR, as well as other cellular and non-cellular standards like A-GNSS. Test procedures for single and diverse receiver devices are described. From the requirements side, only North American bands are covered.

It has to be noted that, due to licensing conditions, testing according to CTIA Test Plans can only be performed by CTIA Authorised Test Laboratories (ATL).

B.3 ETSI

With the introduction of the Radio Equipment Directive (RED), market approval requires certification of UEs/MS to comply with OTA requirements. ETSI is working on harmonised standard taking care of TRP and TRS procedures and requirements, as a revision of:

- ▶ EN 301 908-2 (3G). Version 13.1.1 is listed as RED harmonized standard and includes TRP/TRS procedures and requirements
- ▶ EN 301 908-13 (LTE). Version 13.2.1 is listed as RED harmonized standard and includes TRP/TRS procedures and requirements.
- ▶ EN 301 908-25 (NR) is still officially released.

The procedures in these ETSI standards follow the approach described in documents of 3GPP (see above). When available, requirements are also taken from 3GPP for bands and technologies that are present. Missing values are added in the process of creating the harmonised standard. This activity focuses on frequency bands for ITU-Region 1.

B.4 CCSA

CCSA developed a series of standards for radiated performance including 2G/3G and LTE Technology YD/T 1484 'Measurement method for radiated RF power and receiver performance of wireless device'. The measurement procedures mainly follow the approach as described in documents of 3GPP.

B.5 IEEE

Many of the standards mentioned previously have references to the essential definitions and methods in IEEE Std 149™-2021 - 'IEEE Recommended Practice for Antenna Measurements', where the basis for antenna measurements and methodologies is described.

B.6 Conclusion

3GPP is the most globally recognised SDO of those mentioned above and their test specifications are often referenced by other SDO and in industry-specific standards. Test specifications provided by ETSI are regularly used in the European Union for regulatory compliance testing. Further, CCSA has its focus specifically on industry and market requirements in China, while CTIA provides test plans for industry certification related to PTCRB dedicated to the North American market.

Specifications from 3GPP, CTIA, CCSA and ETSI are mainly applicable to cell phone testing. Nevertheless, CTIA is currently discussing automotive antenna testing in one of their sub-groups.

The IEEE standard 149™-2021 refers to passive antenna testing, and therefore applies generally to any kind of antenna testing.

Annex C: Measurement uncertainty explained

The exact measurement of a quantity is a theoretical concept which cannot be obtained in practical measurements. A measurement is incomplete without an 'uncertainty budget' analysis. The result of a measurement is only an estimate of the value, subject to measurement. The result is complete only when it is accompanied by a quantitative statement of its uncertainty. A measurement uncertainty analysis must be performed on a system setup before starting any antenna measurement.

Uncertainty is that part of the expression of the result of a measurement which states the range of values within which the true value is estimated to lie. The method used to estimate the overall uncertainty is based on statistical analysis and depends on knowing the magnitude and distribution of the individual uncertainty components. Each individual uncertainty component is represented by an estimated standard deviation, or 'standard uncertainty'. All individual uncertainties are categorised as either type A or type B. Type A uncertainties are estimated by statistical methods applied to repeated measurements. Type B uncertainties are estimated using available information and experience. The overall standard uncertainty of a measurement is calculated by combining the standard uncertainties for each of the individual contributions identified. The root of the sum of the squares (RSS) method is always used under the assumption that all contributions are stochastic i.e. independent of each other. The resulting combined standard uncertainty can then be multiplied by a constant K to give the uncertainty limits (bounds), or expanded uncertainty, at a confidence level of xx %.

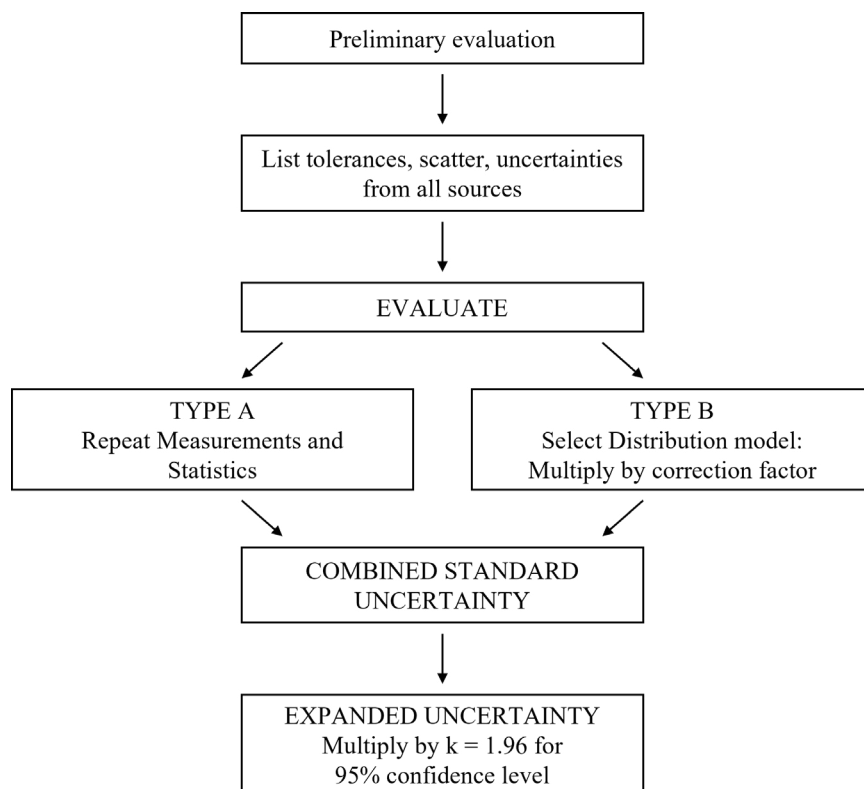

Annex D: Uncertainty considerations

An analysis of the measurement uncertainty needs to be carried out and documented.

The measurement uncertainty of a spherical near-field setup can be divided into two main groups:

1. Near-field measurement uncertainty -> radiation pattern (directivity) measurement (near-field to far-field transformation error terms are included).
2. Gain measurement uncertainty -> power measurement

For many near-field uncertainties, the magnitude of the uncertainty equals the estimated magnitude of the corresponding error.

The following list includes all uncertainty contributors. Most of the measurement uncertainty terms can be found in the NIST 18-term model which is the basis for most uncertainty budgets for near-field antenna measurements, see e.g., [5].

Description of Measurement Uncertainty Contributions				
Type		Contribution		
		Multiprobe Near Field	Singleprobe Near Field	
Stage 2 - AUT Radiation Pattern (Directivity) Measurement Uncertainty				
Mechanical	Static	Probe Array Shape (Radius)	Axes intersection	
		Probe Array AUT Intersection	Axes orthogonality	
		Probe Positions	Probe position	
	Dynamic			Probe trajectory taper
				Probe trajectory ripple
				Probe pointing
				AUT alignment
System/ Electrical		Magnitude/ Phase Drift	Magnitude/ Phase Drift	
		Magnitude/ Phase Noise	Magnitude/ Phase Noise	
		Dynamic Range	Dynamic Range	
		Random Noise	Random Noise	
		Leakage and Crosstalk	Leakage and Crosstalk	
		Amplitude non-Linearity	Amplitude non-Linearity	
		Cable and Rotary Joint	Cable and Rotary Joint	
Stray Signals		Multiple Reflections	Multiple Reflections	
		Reflectivity Level	Reflectivity Level	
		AUT Supporting Structure	AUT Supporting Structure	
Probe		Array Uniformity	Magnitude and Phase Imbalance	
		Probe Pattern	Probe pattern	
		On-axis Cross Polar		
		Magnitude and Phase Imbalance		
Acquisition		Scan Truncation	Scan Truncation	
		Spherical Mode Truncation	Spherical Mode Truncation	
		Sampling Point Offset		
AUT		Power Uncertainty/ Mismatch	Power Uncertainty/ Mismatch	

Stage 1 - Calibration Measurement					
Mechanical	Static	Probe Array Shape (Radius)	Probe Array AUT Intersection	Axes intersection	
		Probe Array AUT Intersection	Probe Positions	Axes orthogonality	
		Probe Positions		Probe position	
	Dynamic				Probe trajectory taper
					Probe trajectory ripple
					Probe pointing error
					AUT alignment
System/ Electrical		Magnitude/ Phase Drift	Magnitude/ Phase Drift	Magnitude/ Phase Drift	
		Magnitude/ Phase Noise	Magnitude/ Phase Noise	Magnitude/ Phase Noise	
		Dynamic Range	Dynamic Range	Dynamic Range	
		Random Noise	Random Noise	Random Noise	
		Leakage and Crosstalk	Leakage and Crosstalk	Leakage and Crosstalk	
		Amplitude non-Linearity	Amplitude non-Linearity	Amplitude non-Linearity	
		Cable and Rotary Joint	Cable and Rotary Joint	Cable and Rotary Joint	
Stray Signals		Multiple Reflections	Multiple Reflections	Multiple Reflections	
		Reflectivity Level	Reflectivity Level	Reflectivity Level	
		AUT Supporting Structure	AUT Supporting Structure	AUT Supporting Structure	
Probe		Array Uniformity			
		On-axis Cross Polar	On-axis Cross Polar	Probe pattern	
		Magnitude and Phase Imbalance	Magnitude and Phase Imbalance	Magnitude and Phase Imbalance	
Acquisition		Scan Truncation	Scan Truncation	Scan Truncation	
		Sampling Point Offset			
		Spherical Mode Truncation	Spherical Mode Truncation	Spherical Mode Truncation	
Reference Antenna Radiated		Reference Gain	Reference Gain	Reference Gain	
		Power Uncertainty/ Mismatch	Power Uncertainty/ Mismatch	Power Uncertainty/ Mismatch	

Below is an example of measurement uncertainty assessment. For each uncertainty term, uncertainty value and probability distribution must be reported.

Multiprobe Near Field Measurement Uncertainty			AUT Gain	Frequency [MHz]
Type	Contribution	Uncertainty Value [dB]	Probability Distribution	Standard Uncertainty [dB]
Stage 2 - AUT Radiation Pattern (Directivity) Measurement Uncertainty				
Mechanical	Probe Array Shape (Radius)			
	Probe Array AUT Intersection			
	Probe Positions			
System/ Electrical	Magnitude/ Phase Drift			
	Magnitude/ Phase Noise			
	Dynamic Range			
	Random Noise			
	Leakage and Crosstalk			
	Amplitude non-Linearity			
	Cable and Rotary Joint			
Stray Signals	Multiple Reflections			
	Reflectivity Level			
	AUT Supporting Structure			

Probe Array	Array Uniformity			
	Probe Pattern			
	On-axis Cross Polar			
	Magnitude and Phase Imbalance			
Acquisition	Scan Truncation			
	Sampling Point Offset			
	Spherical Mode Truncation			
AUT	Power Uncertainty/ Mismatch			
Stage 1 - Calibration Measurement				
Mechanical	Probe Array Shape (Radius)			
	Probe Array AUT Intersection			
	Probe Positions			
System/ Electrical	Magnitude/ Phase Drift			
	Magnitude/ Phase Noise			
	Dynamic Range			
	Random Noise			
	Leakage and Crosstalk			
	Amplitude non-Linearity			
	Cable and Rotary Joint			
Stray Signals	Multiple Reflections			
	Reflectivity Level			
	AUT Supporting Structure			
Probe Array	Array Uniformity			
	On-axis Cross Polar			
	Magnitude and Phase Imbalance			
Acquisition	Scan Truncation			
	Sampling Point Offset			
	Spherical Mode Truncation			
Reference Antenna Radiated	Reference Gain			
	Power Uncertainty/ Mismatch			
	RSS Total Gain Uncertainty [dB]			
	Coverage Factor [95%]			1.96
	Expanded Total Gain Uncertainty [dB]			

A dedicated estimation of error for power-gain measurements is exemplarily given in [1], 8.5 Errors in gain measurements.

5GAA is a multi-industry association to develop, test and promote communications solutions, initiate their standardisation and accelerate their commercial availability and global market penetration to address societal need. For more information such as a complete mission statement and a list of members please see <https://5gaa.org>

